

User's and Service Guide

Agilent Technologies 85058B/E 1.85 mm Calibration Kits



Agilent Technologies

Agilent Part Number: 85058-90005

Printed in USA

Print Date: April 2004

Supersedes: May 2003

© Copyright 2003, 2004 Agilent Technologies, Inc. All rights reserved.

Documentation Warranty

THE MATERIAL CONTAINED IN THIS DOCUMENT IS PROVIDED "AS IS," AND IS SUBJECT TO BEING CHANGED, WITHOUT NOTICE, IN FUTURE EDITIONS. FURTHER, TO THE MAXIMUM EXTENT PERMITTED BY APPLICABLE LAW, AGILENT DISCLAIMS ALL WARRANTIES, EITHER EXPRESS OR IMPLIED WITH REGARD TO THIS MANUAL AND ANY INFORMATION CONTAINED HEREIN, INCLUDING BUT NOT LIMITED TO THE IMPLIED WARRANTIES OF MERCHANTABILITY AND FITNESS FOR A PARTICULAR PURPOSE. AGILENT SHALL NOT BE LIABLE FOR ERRORS OR FOR INCIDENTAL OR CONSEQUENTIAL DAMAGES IN CONNECTION WITH THE FURNISHING, USE, OR PERFORMANCE OF THIS DOCUMENT OR ANY INFORMATION CONTAINED HEREIN. SHOULD AGILENT AND THE USER HAVE A SEPARATE WRITTEN AGREEMENT WITH WARRANTY TERMS COVERING THE MATERIAL IN THIS DOCUMENT THAT CONFLICT WITH THESE TERMS, THE WARRANTY TERMS IN THE SEPARATE AGREEMENT WILL CONTROL.

DFARS/Restricted Rights Notice

If software is for use in the performance of a U.S. Government prime contract or subcontract, Software is delivered and licensed as "Commercial computer software" as defined in DFAR 252.227-7014 (June 1995), or as a "commercial item" as defined in FAR 2.101(a) or as "Restricted computer software" as defined in FAR 52.227-19 (June 1987) or any equivalent agency regulation or contract clause. Use, duplication or disclosure of Software is subject to Agilent Technologies' standard commercial license terms, and non-DOD Departments and Agencies of the U.S. Government will receive no greater than Restricted Rights as defined in FAR 52.227-19(c)(1-2) (June 1987). U.S. Government users will receive no greater than Limited Rights as defined in FAR 52.227-14 (June 1987) or DFAR 252.227-7015 (b)(2) (November 1995), as applicable in any technical data.

Assistance

Product maintenance agreements and other customer assistance agreements are available for Agilent products.

For any assistance, contact Agilent Technologies. Refer to Table 5-1 on page 5-3.

Printing Copies of This Document

To print copies of this document, download the PDF file from the Agilent Web site:

- Go to <http://www.agilent.com>.
- Enter the document's part number (located on the title page) in the **Quick Search** box.
- Click **GO**.

1. General Information

| | |
|---|------|
| Calibration Kit Overview | 1-2 |
| Two Models for Defining Calibration Standards | 1-2 |
| 1.85 mm Calibration Techniques | 1-4 |
| 85058B (Standard) Kit Contents | 1-4 |
| 85058E (Economy) Kit Contents | 1-6 |
| Calibration Definitions | 1-7 |
| Achieving Specified Frequency Performance | 1-7 |
| Offset-Short Calibration Using the 85058B (Standard) Calibration Kit | 1-8 |
| Broadband SOLT Calibration Using the 85058E (Economy) Calibration Kit | 1-9 |
| Network Analyzer Calibrations | 1-10 |
| Calibration Residual Error Specifications | 1-14 |
| Incoming Inspection | 1-17 |
| Recording the Device Serial Numbers | 1-18 |
| Slotted Connectors | 1-20 |
| Clarifying the Sex of a Connector | 1-20 |
| Preventive Maintenance | 1-20 |

2. Specifications

| | |
|---|-----|
| Environmental Requirements | 2-2 |
| Temperature—What to Watch Out For | 2-2 |
| Mechanical Characteristics | 2-3 |
| Pin Depth | 2-3 |
| Electrical Specifications | 2-4 |
| Certification | 2-9 |

3. Use, Maintenance, and Care of the Devices

| | |
|---|------|
| Electrostatic Discharge | 3-2 |
| Visual Inspection | 3-3 |
| Look for Obvious Defects and Damage First | 3-3 |
| Connector Contacts | 3-3 |
| Concentricity | 3-4 |
| Inspect the Mating Plane Surfaces | 3-5 |
| Inspect Female Connectors | 3-5 |
| Cleaning Connectors | 3-6 |
| Gaging Connectors | 3-8 |
| Connector Gage Accuracy | 3-8 |
| When to Gage Connectors | 3-9 |
| Gaging Procedures | 3-10 |
| Connections | 3-14 |
| How to Make a Connection | 3-14 |
| How to Separate a Connection | 3-16 |
| Handling and Storage | 3-16 |

4. Performance Verification

| | |
|------------------------|-----|
| Introduction | 4-2 |
|------------------------|-----|

Contents

How Agilent Verifies the Devices in This Kit 4-2
Recertification 4-3
 How Often to Recertify 4-3
 Where to Send a Kit for Recertification 4-3

5. Troubleshooting

Troubleshooting Process 5-2
Returning a Kit or Device to Agilent 5-3

6. Replaceable Parts

Introduction 6-2

A. Standard Definitions

Version Changes A-2
Standard Class Assignments A-2
 Blank Forms A-9
Nominal Standard Definitions A-11
 Setting the System Impedance A-11
 Blank Forms A-20

1 General Information

Calibration Kit Overview

The Agilent 85058B (Standard) and 85058E (Economy) 1.85 mm calibration kits are used to calibrate Agilent network analyzers up to 67 GHz for measurements of components with 1.85 mm connectors. The 1.85 mm connector is designed such that it may be mated with 2.4 mm connectors.

The 85058B (Standard) is the more accurate of the two calibration kits, containing twelve calibration standards. The 85058E (Economy) kit is less accurate, containing six calibration standards.

The standards in these calibration kits allow you to perform simple 1- or 2-port and TRM (thru-reflect-match) calibrations.

Two Models for Defining Calibration Standards

The 85058 family of calibration kits offers the following two models for defining calibration standards:

- Data-based model
 - ❑ PNA: 85058B and 85058E
 - ❑ 8510: data-based model not available
- Polynomial model
 - ❑ PNA: 85058BP and the 85058EP
 - ❑ 8510: 85058B and 85058E

The PNA family of analyzers offers both the data-based models and the polynomial models as cal kit selections. In contrast, the 8510 family of analyzers offers only the polynomial models as cal kit selections.

Data-Based Model

The data-based model can be used with the PNA but NOT with the 8510 family of analyzers. For the PNA, the data-based model (85058B or 85058E) of each calibration kit provides higher accuracy for describing calibration standards than the polynomial model (85058BP or 85058EP). The data-based nominal S-Parameter model for each calibration standard is generated by using a theoretical derivation or a high accuracy S-Parameter measurement. These nominal S-parameter models are stored as part of the data-based model. Errors that can be the result of polynomial model approximations do not exist.

The data-based models may only be used with the SmartCal (Guided) Calibration method of the Cal Wizard. Using the data-based models with the Unguided Calibration method of the Cal Wizard is not allowed.

The data-based models may NOT be edited with the Advanced Modify Cal Kit dialog box. Attempts to programmatically edit the definitions of the data-based-model calibration standards will result in reported errors (i.e. SCPI Execution Error).

In the PNA's Modify Calibration Class Assignments dialog box¹, the “Expanded Math”

feature is turned ON by default when the 85058B data-based model is selected from a cal kit menu. In order to achieve a more accurate calibration, Expanded Math uses the data at any given frequency from ALL measured standards instead of using only the three standards specified in the class definitions (see Table A-3 on page A-5). If you are using a PNA, it is RECOMMENDED that you use Expanded Math with the 85058B data-based model for the highest accuracy. Expanded Math has no effect with the 85058E data-based model.

Polynomial Model

The polynomial model is the only choice offered by the 8510 family of analyzers to define calibration standards. In contrast, the PNA offers both the data-based and the polynomial models. The polynomial models may be used with SmartCal (Guided) and the Unguided Mechanical Calibration method of the Cal Wizard.

Polynomial models are less accurate than the data-based models. The polynomial models define the calibration standards with traditional four-term polynomial calibration standard modeling parameters. For the PNA, it is NOT RECOMMENDED that the polynomial models be used if the most accurate results are desired.

If you're calibrating over the full frequency range of the calibration kit, you may be prompted to connect some calibration standards more than once. These standards are defined by using multiple polynomial models to achieve the full frequency range of operation.

Unlike the data-based models, the polynomial models allow you to modify the definitions of calibration standards like any other traditional model-based calibration kit. This is accomplished with the Advanced Modify Cal Kit dialog box. For more information on modifying the definitions of the calibration standards, refer to your network analyzer user's guide (8510 family) or online Help (PNA family).

In the Modify Class Assignments dialog box, the "Expanded Math" feature is turned OFF by default when a polynomial model is selected. It is NOT RECOMMENDED that you use Expanded Math with a polynomial model unless the calibration kit includes overlapped banded standards such as a sliding load.

Accuracy Ranking of the 1.85 mm Calibration Kits (item #1 has highest accuracy)

- PNA family:
 1. 85058B (Standard), data-based model
 2. 85058BP (Standard), polynomial model
 3. 85058E (Economy), data-based model
 4. 85058EP (Economy), polynomial model
- 8510 family:
 1. 85058B (Standard), polynomial model

1. Pathway to the Modify Calibration Class Assignments dialog box: Calibration > Advanced Modify Cal Kit > Edit Kit > Class Assignments: Edit.

2. 85058EP (Economy), polynomial model

1.85 mm Calibration Techniques

85058B (Standard) Calibration Kit

- Offset Short Calibration technique
 - ❑ Files:
 - (8510) CK_185MMBA2
 - (PNA) 85058B Data-Based.ckt
 - (PNA) 85058BP Polynomial.ckt
 - ❑ OSL/SSS
 - ❑ “Lowband” definition of lowband load, open, and Short 1

85058E (Economy) Calibration Kit

- Broadband Load Calibration technique
 - ❑ Files:
 - (8510) CK_185MMEA2
 - (PNA) 85058E Data-Based.ckt
 - (PNA) 85058EP Polynomial.ckt
 - ❑ OSL
 - ❑ “Broadband” definition of broadband termination, open, and Short 1

85058B (Standard) Kit Contents

The 85058B (Standard) calibration kit contains the following:

- one pair (male and female) of an offset open
- one pair (male and female) of a lowband load
- four pairs (male and female) of offset shorts
- three adapters
- a 5/16 inch, 90 N-cm (8 in-lb) torque wrench for use on the 1.85 mm connectors
- an open-end wrench for the 8mm flats on some of the components
- a data disk that contains the calibration definitions for the devices in the kit
- two gage sets
- a 10x magnifying glass

Refer to Table 6-1 on page 6-3 and Figure 6-1 on page 6-5 for a complete list of kit contents and their associated part numbers.

Lowband Loads

The best operating region of the load is from DC to 35 GHz. Performance degrades quickly

above 35 GHz.

Offset Opens and Shorts

The offset opens and shorts are built from parts that are machined to the current state-of-the-art in precision machining. The offset short’s inner conductors have a one-piece construction, common with the shorting plane. This construction provides for extremely repeatable connections. The offset opens have inner conductors that are supported by a strong, low-dielectric plastic to provide repeatability and reliability. Both the opens and shorts are constructed so that the pin depth can be controlled very tightly, thereby minimizing phase errors. The length of the offset opens is designed so that the difference in phase of their reflection coefficients is approximately 180 degrees at all frequencies, with respect to offset Short 1.

Different combinations of offset shorts using three different lengths are used to calibrate frequency ranges from 35 to 50 GHz and from 50 to 67 GHz. The calibration coefficients for these offset shorts are optimized for their applicable bandwidths.

How to Identify Devices The shorts, opens, and loads in the kit are identified by the number of rings (or bands) around the body of the device.

- lowband loads have no rings or bands
- 5.4 mm offset short has 1 ring or band and is identified as Short 1
- 6.3 mm offset short has 2 rings or bands and is identified as Short 2
- 7.12 mm offset short has 3 rings or bands and is identified as Short 3
- 7.6 mm offset short has 4 rings or bands and is identified as Short 4
- offset open has 1 ring and is designed to be 180 degrees out of phase with Short 1. In addition, the offset open has a rounded edge to help distinguish it from the shorts (see Figure 1-1).

Figure 1-1 OPEN Calibration Devices: 85058B and 85058E

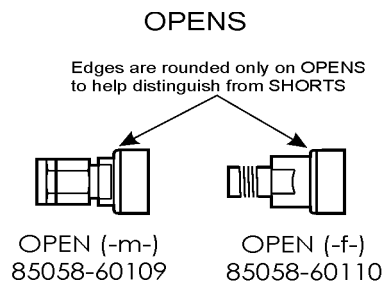

Adapters

Like the other devices in the kit, the adapters are built to very tight tolerances to provide good broadband performance and to ensure stable, repeatable connections.

The adapters are designed (phase matched) so that their nominal electrical lengths are the same, which allows them to be used in calibration procedures for non-insertable devices.

85058E (Economy) Kit Contents

The 85058E (Economy) calibration kit contains the following:

- one pair (male and female) of an offset open, offset short, and a broadband termination
- three adapters
- a 5/16 inch, 90 N-cm (8 in-lb) torque wrench for use on the 1.85 mm connectors
- an open-end wrench for the 8 mm flats on some of the components
- a data disk that contains the calibration definitions for the devices in the kit

Refer to Table 6-1 on page 6-3 and Figure 6-2 on page 6-7 for a complete list of kit contents and their associated part numbers.

Broadband Terminations

The broadband terminations are instrument-grade, 50 Ω terminations that have been optimized for performance up to 67 GHz. The rugged internal structure provides for highly repeatable connections. A distributed resistive element on sapphire provides excellent stability and return loss. The smooth body of the broadband termination allows it to be easily distinguished from an open and short.

Offset Opens and Shorts

The opens and shorts are built from parts that are machined to the current state-of-the-art precision machining.

The short's inner conductors have a one-piece construction, common with the shorting plane. This construction provides for extremely repeatable connections.

The offset opens have inner conductors that are supported by a strong, low-dielectric plastic to provide repeatability and reliability.

Both the opens and shorts are constructed so that the pin depth can be controlled very tightly, thereby minimizing phase errors. The opens and shorts have offsets. The lengths of these offsets are designed so that the difference in phase of their reflection coefficients is approximately 180 degrees at all frequencies. The open has a rounded edge to help distinguish it from the shorts (see Figure 1-1 on page 1-5).

Adapters

Like the other devices in the kit, the adapters are built to very tight tolerances to provide good broadband performance and to ensure stable, repeatable connections.

The adapters are designed so that their nominal electrical lengths are the same, which allows them to be used in calibration procedures for non-insertable devices.

Calibration Definitions

The calibration kit must be selected prior to performing a calibration. In addition, the calibration definitions for the devices in the kit must be installed in the analyzer if not permanently stored in the internal memory or hard drive.

The calibration definitions can be:

- recalled from the analyzer (if stored in internal memory or the hard drive)
- loaded from the provided disk
- entered from the front panel (polynomial models only)

Refer to your network analyzer user's guide (8510 family) or online Help (PNA family) for instructions on selecting the calibration kit, installing (if necessary) the calibration definitions, and performing a calibration.

Equipment Required but Not Supplied

Gage sets (not provided with the 85058E), adapters, ESD protection devices, and various connector cleaning supplies are *not* included in the calibration kit but are required to ensure successful operation of the calibration kit. Refer to Table 6-3 on page 6-8 for ordering information.

Achieving Specified Frequency Performance

The standards in this calibration kit allow you to perform 1- or 2-port and TRM (thru-reflect-match) calibrations.

| | |
|-------------|---|
| NOTE | For best results, before beginning calibration refer to "Clarifying the Sex of a Connector" on page 1-20. |
|-------------|---|

Offset-Short Calibration Using the 85058B (Standard) Calibration Kit

Table 1-1 Offset-Short Calibration Standards

| Calibration Kit Label: | | | | | | |
|---|---|------------------------------|-------------------------------|-------------------------------|---|-----------------------------------|
| 8510: 1.85MMBA.2 PNA: 85058B Data-Based 85058BP Polynomial | | | | | | |
| Disk File Name: | | | | | | |
| 8510: CK_185MMBA2 PNA: 85058B Data-Based.ckt 85058BP Polynomial.ckt | | | | | | |
| Frequency Range | Calibration Technique | “Open” Standard (Reflection) | “Short” Standard (Reflection) | “Load” Standard (Reflection) | “Thru” Standard (not used for 1-port cal) | “Isolation” Standard ^a |
| DC–35 GHz | SOLT ^b | Open | Short 1 | Load LB | Thru | Load BB ^c |
| 35–50 GHz | Offset Shorts | Short 2 | Short 1 | Short 4 | Thru | Load BB ^c |
| 50–67 GHz | Offset Shorts | Short 3 | Short 1 | Short 4 | Thru | Load BB ^c |
| To Combine Frequency Ranges ^d | | | | | | |
| DC–35 GHz | | | | | | |
| | SOLT ^b and Offset Shorts | Open | Short 1 | Load LB | Thru | Load BB ^c |
| 35–67 GHz | | | | | | |
| | Offset Shorts | Short 2 | Short 1 | Short 4 Short 2 | Thru | Load BB ^c |
| DC–67 GHz | | | | | | |
| | SOLT ^b and Offset Shorts | Open Short 3 | Short 3 Short 1 | Load LB Short 4 Short 2 | Thru | Load BB ^c |

- For best measurement results, the isolation standard should be the equivalent impedance of the device under test.
- SOLT = Short, Open, Load and Thru standards
- Load BB is the lowband load using a broadband load definition.
- Combinations of the calibration methods shown in the upper half of Table 1-1 are used to calibrate over the frequency ranges shown in the lower half of the table.

Broadband SOLT Calibration Using the 85058E (Economy) Calibration Kit

The Broadband SOLT calibration is the only calibration technique available with the 85058E (Economy) kit. You can calibrate from DC to 67 GHz using the standards in Table 1-2.

Table 1-2 85058E (Economy) Broadband SOLT^a Calibration Standards

| Calibration Kit Label: | | | | | | |
|---|-----------------------|------------------|---------------------|---------------------|---|----------------------|
| 8510: 1.85MEA.2 PNA: 85058E Data-Based 85058EP Polynomial | | | | | | |
| Disk File Name: | | | | | | |
| 8510: CK_185MMEA2 PNA: 85058E Data-Based.ckt 85058EP Polynomial.ckt | | | | | | |
| Frequency Range | Calibration Technique | “Open” Standard | “Short” Standard | “Load” Standard | “Thru” Standard (not used for 1-port cal) | “Isolation” Standard |
| DC–67 GHz | SOLT | Open (broadband) | Short 1 (broadband) | Load BB (broadband) | Thru | Load BB |

a. SOLT = Short, Open, Load and Thru standards

Network Analyzer Calibrations

To calibrate a Network Analyzer, use the following combinations of standards listed in Table 1-3 and Table 1-4 (for 1-port calibrations), and Table 1-5 and Table 1-6 (for 2-port calibrations) for the best results. For more information, refer to Table 1-1 on page 1-8 and Table 1-2 on page 1-9.

Table 1-3 85058B (Standard) 1-Port Calibration

| Frequency Range | Calibration Type | Calibration Standards | Standard Numbers ^a |
|---|------------------|-----------------------|-------------------------------|
| 8510: CK_185MMBA2 PNA: 85058B Data-Based.ckt 85058BP Polynomial.ckt | | | |
| DC to 35 Ghz | Open | Open | 2, 4 |
| | Short | Short 1 | 1, 3 |
| | Load | Load | 9, 24 ^b |
| 35 to 50 GHz | Offset Short | Short 1 | 12, 16 |
| | Offset Short | Short 2 | 13, 17 |
| | Offset Short | Short 4 | 15, 19 |
| 50 to 67 GHz | Offset Short | Short 1 | 12, 16 |
| | Offset Short | Short 2 | 13, 17 |
| | Offset Short | Short 3 | 14, 18 |

- a. Standard numbers reference the line numbers in the Standard Definitions tables, located in the Appendix.
- b. PNA-family only.

Table 1-4 85058E (Economy) 1-Port Calibration

| Frequency Range | Calibration Type | Calibration Standards | Standard Numbers ^a |
|---|------------------|----------------------------|-------------------------------|
| 8510: CK_185MMEA2 PNA: 85058E Data-Based.ckt 85058EP Polynomial.ckt | | | |
| DC to 67 GHz | Open | Open | 2, 4 |
| | Short | Short 1 | 1, 3 |
| | Load | Termination (broadband) | 9, 24 ^b |

- a. Standard numbers reference the line numbers in the Standard Definitions tables located in the Appendix.
- b. PNA-family only.

Table 1-5 85058B (Standard) 2-Port Calibration^a

| Frequency Range | Calibration Type | Calibration Standards | Standard Numbers |
|----------------------------|------------------|-----------------------|--|
| 8510: CK_185MMBA2 | | | |
| PNA: 85058B Data-Based.ckt | | | |
| 85058BP Polynomial.ckt | | | |
| DC to 35 GHz | Open | Open | 2, 4 |
| | Short | Short 1 | 1, 3 |
| | Load | Load | 9, 24 ^b |
| | Thru | Thru | 11 |
| 35 to 50 GHz | Offset Short | Short 1 | 12, 16 |
| | Offset Short | Short 2 | 13, 17 |
| | Offset Short | Short 4 | 15, 19 |
| | Thru | Thru | 11 |
| 50 to 67 GHz | Offset Short | Short 1 | 12, 16 |
| | Offset Short | Short 2 | 13, 17 |
| | Offset Short | Short 3 | 14, 18 |
| | Thru | Thru | 11 |
| DC to 67 GHz | Thru | Thru | 11 |
| | Reflect | Short 1 | 5, 7 |
| | Match | Load | 10 ^{b,c} , 21 ^d , 22 ^{b,c} |

- a. Standard numbers reference the line numbers in the Standard Definitions tables, located in the Appendix.
- b. PNA-family only.
- c. Polynomial-model only (85058BP).
- d. 8510-family only.

Table 1-6 85058E (Economy) 2-Port Calibration^a

| Frequency Range | Calibration Type | Calibration Standards | Standard Numbers |
|----------------------------|------------------|-------------------------|--|
| 8510: CK_185MMEA2 | | | |
| PNA: 85058E Data-Based.ckt | | | |
| 85058EP Polynomial.ckt | | | |
| DC to 67 GHz | Open | Open | 2, 4 |
| | Short | Short 3 | 1, 3 |
| | Load | Termination (broadband) | 9, 24 ^b |
| | Thru | Thru | 11 |
| DC to 67 GHz | Thru | Thru | 11 |
| | Reflect | Short 1 | 1, 3 |
| | Match | Termination (broadband) | 9 ^b , 14 ^c , 24 ^b |

- a. Standard numbers reference the line numbers in the Standard Definitions tables, located in the Appendix.
b. PNA-family only.
c. 8510-family only.

Calibration Residual Error Specifications

Please download our free Vector Network Analyzer Uncertainty Calculator from http://www.agilent.com/find/na_calculator.

Table 1-7 85058B (Standard) Residual System Calibration Error Specifications

| Parameter | Cal Method ^a | Frequency Range | Residuals | | |
|---------------------|-------------------------|-----------------|--|--|--|
| | | | PNA ^b | | PNA/8510 ^c |
| | | | Data-Based Model ^d Expanded Math Selected | Data-Based Model ^d Expanded Math Unselected | Polynomial Model ^d Expanded Math Unselected |
| Directivity | OSL | DC to 2 GHz | 35 | 35 | 35 |
| | OSL | 2 to 10 GHz | 41 | 35 | 35 |
| | OSL | 10 to 20 GHz | 38 | 35 | 35 |
| | OSL | 20 to 35 GHz | 37 | 30 | 30 |
| | SSS | 35 to 50 GHz | 37 | 36 | 33 |
| | SSS | 50 to 67 GHz | 34 | 34 | 31 |
| Source Match | OSL | DC to 2 GHz | 34 | 34 | 34 |
| | OSL | 2 to 10 GHz | 44 | 32 | 31 |
| | OSL | 10 to 20 GHz | 40 | 30 | 30 |
| | OSL | 20 to 35 GHz | 41 | 26 | 26 |
| | SSS | 35 to 50 GHz | 42 | 41 | 36 |
| | SSS | 50 to 67 GHz | 40 | 39 | 33 |
| Reflection Tracking | OSL | DC to 2 GHz | 0.019 | 0.019 | 0.020 |

Table 1-7 (Continued) 85058B (Standard) Residual System Calibration Error

| Parameter | Cal Method ^a | Frequency Range | Residuals | | |
|-----------|-------------------------|-----------------|--|--|--|
| | | | PNA ^b | | PNA/8510 ^c |
| | | | Data-Based Model ^d Expanded Math Selected | Data-Based Model ^d Expanded Math Unselected | Polynomial Model ^d Expanded Math Unselected |
| | OSL | 2 to 10 GHz | 0.010 | 0.012 | 0.017 |
| | OSL | 10 to 20 GHz | 0.033 | 0.033 | 0.033 |
| | OSL | 20 to 35 GHz | 0.033 | 0.033 | 0.035 |
| | SSS | 35 to 50 GHz | 0.027 | 0.028 | 0.035 |
| | SSS | 50 to 60 GHz | 0.030 | 0.038 | 0.040 |
| | SSS | 60 to 67 GHz | 0.030 | 0.038 | 0.045 |

- a. For Expanded Math, all mateable standards in class are measured for the calibration. For example, using the OSL cal method with expanded math measures OSSSSL.
- b. Using the *85058B Data-Based.ckt* (PNA) calibration definitions file.
- c. Using one of the following calibration definitions files: *85058BP Polynomial.ckt* (PNA) or the *CK_185MMBA2* (8510).
- d. Refer to "Two Models for Defining Calibration Standards," on page 1-2.

Table 1-8 85058E (Economy) Residual System Calibration Error Specifications

| Parameter | Cal Method ^a | Frequency Range | Residuals | |
|---------------------|-------------------------|-----------------|-------------------------------------|--|
| | | | PNA Data-Based Model ^{b,c} | PNA/8510 Polynomial Model ^{b,d} |
| Directivity | OSL | DC to 2 GHz | 30 | 30 |
| | OSL | 2 to 10 GHz | 30 | 30 |
| | OSL | 10 to 20 GHz | 30 | 30 |
| | OSL | 20 to 35 GHz | 30 | 30 |
| | OSL | 35 to 50 GHz | 28 | 28 |
| | OSL | 50 to 67 GHz | 28 | 28 |
| Source Match | OSL | DC to 2 GHz | 28 | 28 |
| | OSL | 2 to 10 GHz | 28 | 28 |
| | OSL | 10 to 20 GHz | 27 | 27 |
| | OSL | 20 to 35 GHz | 26 | 23 |
| | OSL | 35 to 60 GHz | 24 | 22 |
| | OSL | 60 to 67 GHz | 24 | 23 |
| Reflection Tracking | OSL | DC to 2 GHz | 0.023 | 0.025 |
| | OSL | 2 to 10 GHz | 0.021 | 0.027 |
| | OSL | 10 to 20 GHz | 0.029 | 0.035 |
| | OSL | 20 to 35 GHz | 0.028 | 0.035 |

Table 1-8 (Continued) 85058E (Economy) Residual System Calibration Error

| Parameter | Cal Method ^a | Frequency Range | Residuals | |
|-----------|-------------------------|-----------------|-------------------------------------|--|
| | | | PNA Data-Based Model ^{b,c} | PNA/8510 Polynomial Model ^{b,d} |
| | OSL | 35 to 60 GHz | 0.052 | 0.062 |
| | OSL | 60 to 67 GHz | 0.055 | 0.055 |

- a. Expanded Math has no effect with the 85058E data-based model or the 85058EP polynomial model.
- b. Refer to "Two Models for Defining Calibration Standards," on page 1-2.
- c. Using the *85058E Data-Based.ckt* (PNA) calibration definitions file.
- d. Using one of the following calibration definitions files:
85058EP Polynomial.ckt (PNA) or the *CK_185MMEA2* (8510).

Incoming Inspection

Verify that the shipment is complete by referring to Figure 6-1 on page 6-5 or Figure 6-2 on page 6-7.

Check for damage. The foam-lined storage case provides protection during shipping.

If the case or any device appears damaged, or if the shipment is incomplete, contact Agilent. See Table 5-1 on page 5-3. Agilent will arrange for repair or replacement of incomplete or damaged shipments without waiting for a settlement from the transportation company.

When you send the kit or device to Agilent, include a service tag (found near the end of this manual) with the following information:

- your company name and address
- the name of a technical contact person within your company, and the person's complete phone number
- the model number and serial number of the kit
- the part number and serial number of the device
- the type of service required
- a *detailed* description of the problem

Recording the Device Serial Numbers

In addition to the kit serial number, the devices in this kit are individually serialized (serial numbers are labeled onto the body of each device). Record these serial numbers in Table 1-9 for the 85058B (Standard) and Table 1-9 for the 85058E (Economy). Recording the serial numbers will prevent confusing the devices in this kit with similar devices in other kits.

Table 1-9 Serial Number Record for 85058B (Standard)

| Device | Serial Number |
|----------------------------|---------------|
| Calibration kit | _____ |
| Lowband load -m- | _____ |
| Lowband load -f- | _____ |
| Offset open -m- | _____ |
| Offset open -f- | _____ |
| 5.4 mm offset short 1 -m- | _____ |
| 5.4 mm offset short 1 -f- | _____ |
| 6.3 mm offset short 2 -m- | _____ |
| 6.3 mm offset short 2 -f- | _____ |
| 7.12 mm offset short 3 -m- | _____ |
| 7.12 mm offset short 3 -f- | _____ |
| 7.6 mm offset short 4 -m- | _____ |
| 7.6 mm offset short 4 -f- | _____ |
| Adapter m-f | _____ |
| Adapter m-m | _____ |
| Adapter f-f | _____ |

Table 1-10 Serial Number Record for 85058E (Economy)

| Device | Serial Number |
|---------------------------|---------------|
| Calibration kit | _____ |
| Broadband termination -m- | _____ |
| Broadband termination -f- | _____ |
| Open -m- | _____ |
| Open -f- | _____ |
| 5.4 mm offset short -m- | _____ |
| 5.4 mm offset short -f- | _____ |
| Adapter m-f | _____ |
| Adapter m-m | _____ |
| Adapter f-f | _____ |

Slotted Connectors

The female connectors in this kit have slotted contacts. Therefore, the female devices are instrument grade. Unlike precision slotless connectors, the slotted contacts prevent the devices from being classified as metrology grade.

With slotted connectors, the connected male device partially determines the connector impedance of the female device by flaring the contact fingers and consequently varying the diameter of the female center conductor. Precision slotless connectors prevent diameter variations in the female center conductor, therefore allowing greater control over connector impedance.

Clarifying the Sex of a Connector

In this manual and in the prompts of the PNA calibration wizard, the sex of calibration devices and adapters is referred to in terms of the calibration device connector. For example, the label OPEN –m– refers to a male open with a male connector.

8510-series, 872x, and 875x ONLY: In contrast, during a measurement calibration, the network analyzer softkey menus label a 1.85 mm calibration device with reference to the sex of the analyzer's test port connector—not the calibration device connector. For example, the label SHORT (F) refers to the short that is to be connected to the female test port. This will be a male short from the calibration kit.

Connector gages are referred to in terms of the connector that it measures. For instance, a male connector gage has a female connector on the gage so that it can measure male devices.

Preventive Maintenance

The best techniques for maintaining the integrity of the devices in this kit include:

- routine visual inspection
- cleaning
- proper gaging
- proper connection techniques

All of the above are described in Chapter 3. Failure to detect and remove dirt or metallic particles on a mating plane surface can degrade repeatability and accuracy and can damage any connector mated to it. Improper connections, resulting from pin depth values being out of the *observed* limits (see Table on page 2-4), or from bad connections, can also damage these devices.

2 Specifications

Environmental Requirements

Table 2-1 Environmental Requirements

| Parameter | Limits |
|--|--|
| Operating temperature ^a | +20 °C to +26 °C (+68 °F to +79 °F) |
| Error-corrected temperature range ^b | ±1 °C of measurement calibration temperature |
| Storage temperature | -40 °C to +75 °C (-40 °F to +167 °F) |
| Altitude | |
| Operation | < 4,500 meters (≈15,000 feet) |
| Storage | < 15,000 meters (≈50,000 feet) |
| Relative humidity | Always non-condensing |
| Operation | 0 to 80% (26 °C maximum dry bulb) |
| Storage | 0 to 90% |

- a. The temperature range over which the calibration standards maintain conformance to their specifications.
- b. The allowable network analyzer ambient temperature drift during measurement calibration and during measurements when the network analyzer error correction is turned on. Also, the range over which the network analyzer maintains its specified performance while correction is turned on.

Temperature—What to Watch Out For

Changes in temperature can affect electrical characteristics. Therefore, the operating temperature is a critical factor in performance. During a measurement calibration, the temperature of the calibration devices must be stable and within the range specified in Table 2-1.

IMPORTANT Avoid unnecessary handling of the devices during calibration because your fingers are a heat source.

Performance verification and measurements of devices under test need not be performed within the operating temperature range of the calibration devices, but they must be within the error-corrected temperature of the network analyzer (± 1 °C of the measurement calibration temperature). For example, if the calibration is performed at +20 °C, the error-corrected temperature range is +19 °C to +21 °C. It is then appropriate to perform measurements and performance verifications at +19 °C, which is outside the operating temperature range of the calibration devices, since only the actual calibration must be performed within the operating temperature range.

Mechanical Characteristics

Mechanical characteristics such as center conductor protrusion and pin depth are *not* performance specifications. They are, however, important supplemental characteristics related to electrical performance. Agilent Technologies verifies the mechanical characteristics of the devices in this kit with special gaging processes and electrical testing. This ensures that the device connectors do not exhibit any improper pin depth when the kit leaves the factory.

“Gaging Procedures” on page 3-10 explains how to use gages to determine if the kit devices have maintained their mechanical integrity. (Refer to Table 2-2 on page 2-4 for typical and observed pin depth limits.)

Pin Depth

Pin depth is the distance the center conductor mating plane differs from being flush with the outer conductor mating plane. See Figure 2-1 The pin depth of a connector can be in one of two states: either protruding or recessed.

Protrusion is the condition in which the center conductor extends beyond the outer conductor mating plane. This condition will indicate a positive value on the connector gage.

Recession is the condition in which the center conductor is set back from the outer conductor mating plane. This condition will indicate a negative value on the connector gage.

Figure 2-1 Connector Pin Depth

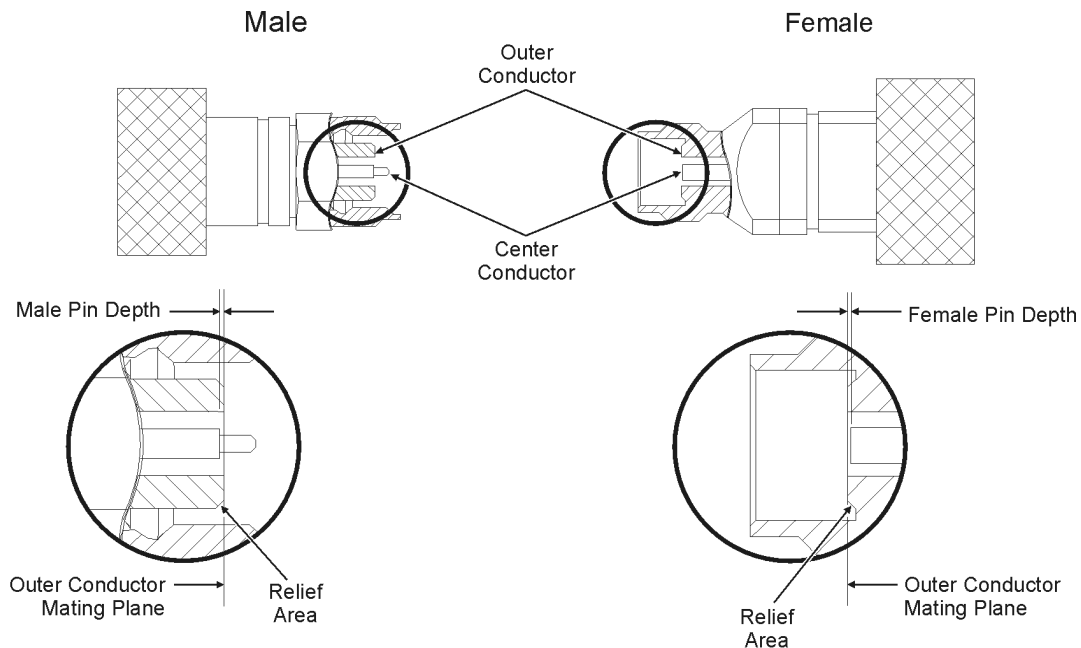

conn185_new

Electrical Specifications

The pin depth value of each calibration device in the kit is not specified, but is an important mechanical parameter. The electrical performance of the device depends, to some extent, on its pin depth. The electrical specifications for each device in the kit take into account the effect of pin depth on the device's performance. Table 2-2 on page 2-4 lists the typical pin depths and measurement uncertainties, and provides observed pin depth limits for the devices in the kit. If the pin depth of a device does not measure within the *observed* pin depth limits, it may be an indication that the device fails to meet electrical specifications. Refer to Figure 2-1 for a visual representation of proper pin depth (slightly recessed).

Table 2-2 Pin Depth Limit

| Device | Typical Pin Depth | Measurement Uncertainty ^a | Observed Pin Depth Limits ^b |
|------------------------------------|--|--|--|
| Opens | -0.005 to -0.015 mm -0.0002 to -0.00059 in | +0.0030 to -0.0030 mm +0.00012 to -0.00012 in | -0.0020 to -0.0180 mm -0.00008 to -0.00071 in |
| Shorts | 0 to -0.0127 mm 0 to -0.0005 in | +0.0015 to -0.0015 mm +0.00006 to -0.00006 in | +0.0015 to -0.0142 mm +0.00006 to -0.00056 in |
| Fixed Loads and Terminations | -0.0025 to -0.0203 mm -0.0001 to -0.0008 in | +0.0030 to -0.0030 mm +0.00012 to -0.00012 in | +0.0005 to -0.0233 mm +0.00002 to -0.00092 in |
| Adapters | 0 to -0.0381 mm 0 to -0.0015 in | +0.0030 to -0.0030 mm +0.00012 to -0.00012 in | +0.0030 to -0.0411 mm +0.00012 to -0.00162 in |

- a. Approximately +2 sigma to -2 sigma of gage uncertainty based on studies done at the factory according to recommended procedures.
- b. Observed pin depth limits are the range of observation limits seen on the gage reading due to measurement uncertainty. The depth could still be within specifications.

Electrical Specifications

The electrical specifications in Table 2-3 through Table 2-4 apply to the devices in your calibration kit when connected with an Agilent precision interface.

Table 2-3 85058B (Standard) Electrical Specifications for 1.85 mm Devices

| Device | Frequency | Parameter | Specifications | | | |
|--------------|---------------------------|--|------------------|------------------|------------------|------------------|
| | | | Male | | Female | |
| | | | Polynomial Model | Data-Based Model | Polynomial Model | Data-Based Model |
| Lowband load | DC to 10 GHz | Return Loss (dB) | 36 | 36 | 35 | 35 |
| | 10 to 20 GHz | | 34 | 34 | 34 | 34 |
| | 20 to 35 GHz | | 31 | 31 | 29 | 29 |
| | 35 to 60 GHz ^a | | 22 | 22 | 12 | 12 |
| | 60 to 67 GHz ^a | | 19 | 19 | 10 | 10 |
| Open | DC to 10 GHz | Deviation from Nominal Phase (degrees) | 2.2 | 2.0 | 2.7 | 2.5 |
| | 10 to 35 GHz | | 3.2 | 3.0 | 3.7 | 3.5 |
| | 35 to 50 GHz | | NA ^b | 3.0 | NA ^b | 3.5 |
| | 50 to 67 GHz | | NA ^b | 4.5 | NA ^b | 5.0 |
| Short 1 | DC to 20 GHz | Deviation from Nominal Phase (degrees) | 1.7 | 1.5 | 1.7 | 1.5 |
| | 20 to 30 GHz | | 2.2 | 2.0 | 2.2 | 2.0 |
| | 30 to 35 GHz | | 2.2 | 2.0 | 2.7 | 2.5 |
| | 35 to 40 GHz | | NA ^b | 2.0 | NA ^b | 2.5 |

Table 2-3 (Continued) **85058B (Standard) Electrical Specifications for 1.85 mm**

| Device | Frequency | Parameter | Specifications | | | |
|---------|--------------|--|------------------|------------------|------------------|------------------|
| | | | Male | | Female | |
| | | | Polynomial Model | Data-Based Model | Polynomial Model | Data-Based Model |
| | 40 to 50 GHz | | NA ^b | 2.0 | NA ^b | 3.5 |
| | 50 to 67 GHz | | NA ^b | 3.0 | NA ^b | 4.0 |
| Short 2 | DC to 20 GHz | Deviation from Nominal Phase (degrees) | NA ^b | 1.5 | NA ^b | 1.5 |
| | 20 to 30 GHz | | NA ^b | 2.0 | NA ^b | 2.0 |
| | 30 to 35 GHz | | NA ^b | 2.0 | NA ^b | 2.5 |
| | 35 to 40 GHz | | 2.4 | 2.0 | 2.9 | 2.5 |
| | 40 to 50 GHz | | 2.6 | 2.0 | 4.1 | 3.5 |
| | 50 to 67 GHz | | 3.6 | 3.0 | 4.6 | 4.0 |
| Short 3 | DC to 20 GHz | Deviation from Nominal Phase (degrees) | NA ^b | 1.5 | NA ^b | 1.5 |
| | 20 to 30 GHz | | NA ^b | 2.0 | NA ^b | 2.0 |
| | 30 to 35 GHz | | NA ^b | 2.0 | NA ^b | 2.5 |
| | 35 to 40 GHz | | 2.4 | 2.0 | 2.9 | 2.5 |
| | 40 to 50 GHz | | 2.6 | 2.0 | 4.1 | 3.5 |

Table 2-3 (Continued) 85058B (Standard) Electrical Specifications for 1.85 mm

| Device | Frequency | Parameter | Specifications | | | |
|---------|--------------|--|------------------|------------------|------------------|------------------|
| | | | Male | | Female | |
| | | | Polynomial Model | Data-Based Model | Polynomial Model | Data-Based Model |
| | 50 to 67 GHz | | 4.4 | 3.0 | 5.4 | 4.0 |
| Short 4 | DC to 20 GHz | Deviation from Nominal Phase (degrees) | NA ^b | 1.5 | NA ^b | 1.5 |
| | 20 to 30 GHz | | NA ^b | 2.0 | NA ^b | 2.0 |
| | 30 to 35 GHz | | NA ^b | 2.0 | NA ^b | 2.5 |
| | 35 to 40 GHz | | 2.7 | 2.0 | 2.9 | 2.5 |
| | 40 to 50 GHz | | 3.1 | 2.0 | 4.6 | 3.5 |
| | 50 to 67 GHz | | 4.2 | 3.0 | 5.2 | 4.0 |

| Device | Frequency | Parameter | Specifications | |
|----------|----------------|-----------|------------------|---------------------|
| | | | Return Loss (dB) | Insertion Loss (dB) |
| Adapters | DC to 4 GHz | | 33 | 0.3 |
| | 4 to 26.5 GHz | | 24 | 0.5 |
| | 26.5 to 50 GHz | | 22 | 0.7 |
| | 50 to 67 GHz | | 20 | 0.9 |

- a. Typical performance.
- b. This cal device is not used in this frequency range when your calibration is using a polynomial model with Expanded Math unselected. Refer to “Two Models for Defining Calibration Standards” on page 1-2.

Table 2-4 85058E (Economy) Electrical Specifications for 1.85 mm Devices

| Device | Frequency | Parameter | Specifications | | | |
|-----------------------|--------------|--|------------------|------------------|------------------|------------------|
| | | | Male | | Female | |
| | | | Polynomial Model | Data-Based Model | Polynomial Model | Data-Based Model |
| Broadband Termination | DC to 35 GHz | Return Loss (dB) | 30 | 30 | 30 | 30 |
| | 35 to 67 GHz | | 28 | 28 | 28 | 28 |
| Open | DC to 10 GHz | Deviation from Nominal Phase (degrees) | 2.5 | 2.0 | 3.0 | 2.5 |
| | 10 to 50 GHz | | 4.0 | 3.0 | 4.5 | 3.5 |
| | 50 to 67 GHz | | 5.5 | 4.5 | 6.0 | 5.0 |
| Short 1 | DC to 20 GHz | Deviation from Nominal Phase (degrees) | 2.0 | 1.5 | 2.0 | 1.5 |
| | 20 to 30 GHz | | 3.0 | 2.0 | 3.0 | 2.0 |
| | 30 to 40 GHz | | 3.0 | 2.0 | 3.5 | 2.5 |
| | 40 to 50 GHz | | 3.0 | 2.0 | 4.5 | 3.5 |
| | 50 to 67 GHz | | 4.0 | 3.0 | 5.0 | 4.0 |

Table 2-4 (Continued) 85058E (Economy) Electrical Specifications for 1.85 mm Devices

| Device | Frequency | Parameter | Specifications | |
|----------|----------------|-----------|------------------|---------------------|
| | | | Return Loss (dB) | Insertion Loss (dB) |
| Adapters | DC to 4 GHz | | 33 | 0.3 |
| | 4 to 26.5 GHz | | 24 | 0.5 |
| | 26.5 to 50 GHz | | 22 | 0.7 |
| | 50 to 67 GHz | | 20 | 0.9 |

Certification

Agilent Technologies certifies that this product met its published specifications at the time of shipment from the factory. Agilent further certifies that its calibration measurements are traceable to the United States National Institute of Standards and Technology (NIST) to the extent allowed by the institute's calibration facility, and to the calibration facilities of other International Standards Organization members. See "How Agilent Verifies the Devices in This Kit," on page 4-2 for more information.

Specifications
Electrical Specifications

3 Use, Maintenance, and Care of the Devices

Electrostatic Discharge

Protection against ESD (electrostatic discharge) is essential while connecting, inspecting, or cleaning connectors attached to a static-sensitive circuit (such as those found in test sets).

Static electricity can build up on your body and can easily damage sensitive internal circuit elements when discharged. Static discharges too small to be felt can cause permanent damage. Devices such as calibration components and devices under test (DUTs), can also carry an electrostatic charge. To prevent damage to the test set, components, and devices:

- *always* wear a grounded wrist strap having a 1 M Ω resistor in series with it when handling components and devices or when making connections to the test set.
- *always* use a grounded, conductive table mat while making connections.
- *always* wear a heel strap when working in an area with a conductive floor. If you are uncertain about the conductivity of your floor, wear a heel strap.
- *always* ground yourself before you clean, inspect, or make a connection to a static-sensitive device or test port. You can, for example, grasp the grounded outer shell of the test port or cable connector briefly.
- *always* ground the center conductor of a test cable before making a connection to the analyzer test port or other static-sensitive device. This can be done as follows:
 1. Connect a short (from your calibration kit) to one end of the cable to short the center conductor to the outer conductor.
 2. While wearing a grounded wrist strap, grasp the outer shell of the cable connector.
 3. Connect the other end of the cable to the test port.
 4. Remove the short from the cable.

Refer to Chapter 6 for part numbers and instructions for ordering ESD protection devices.

Figure 3-1 ESD Protection Setup

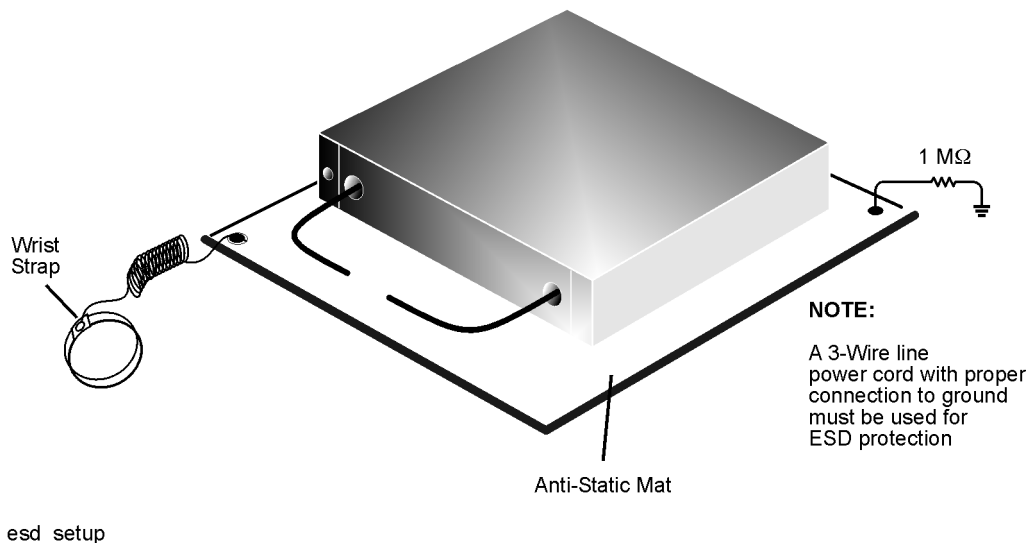

Visual Inspection

Visual inspection and, if necessary, cleaning should be done every time a connection is made. Metal particles from the connector threads may fall into the connector when it is disconnected. One connection made with a dirty or damaged connector can damage both connectors beyond repair.

In some cases, magnification is necessary to see damage on a connector; a magnifying device with a magnification of $\geq 10\times$ is recommended. (A magnifying glass is supplied with the 85058B (Standard) kit.) However, not all defects that are visible only under magnification will affect the electrical performance of the connector. Use the following guidelines when evaluating the integrity of a connector.

Look for Obvious Defects and Damage First

Examine the connectors first for obvious defects and damage: badly worn plating on the connector interface, deformed threads, or bent, broken, or misaligned center conductors. Connector nuts should move smoothly and be free of burrs, loose metal particles, and rough spots.

What Causes Connector Wear?

Connector wear is caused by connecting and disconnecting the devices. The more use a connector gets, the faster it wears and degrades. The wear is greatly accelerated when connectors are not kept clean, or are connected incorrectly.

Connector wear eventually degrades performance of the device. Calibration devices should have a long life if their use is on the order of a few times per week. Replace devices with worn connectors.

The test port connectors on the network analyzer test set may have many connections each day, and are therefore more subject to wear. It is recommended that an adapter be used as a test port saver to minimize the wear on the test set's test port connectors.

Connector Contacts

See Figure 3-2 on page 3-4 for visual guidelines when evaluating the contact integrity of a connector.

NOTE Notice the location of the cross hairs in relationship to the center of the figures.

Figure 3-2 Contact Integrity

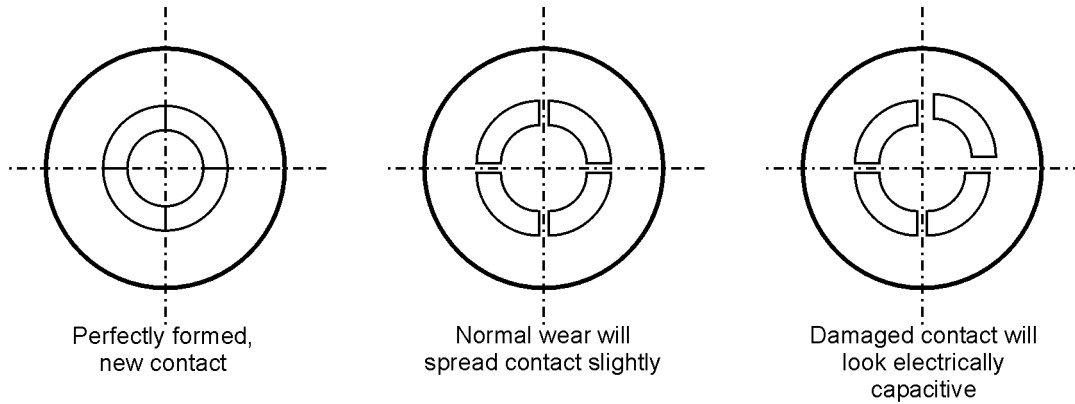

integ

Concentricity

Figure 3-3 and Figure 3-4 show the concentricity of both the male and female 1.85 mm connectors. Inspect the connectors with a minimum magnification of 10X.

Figure 3-3 Concentricity of a Female Connector

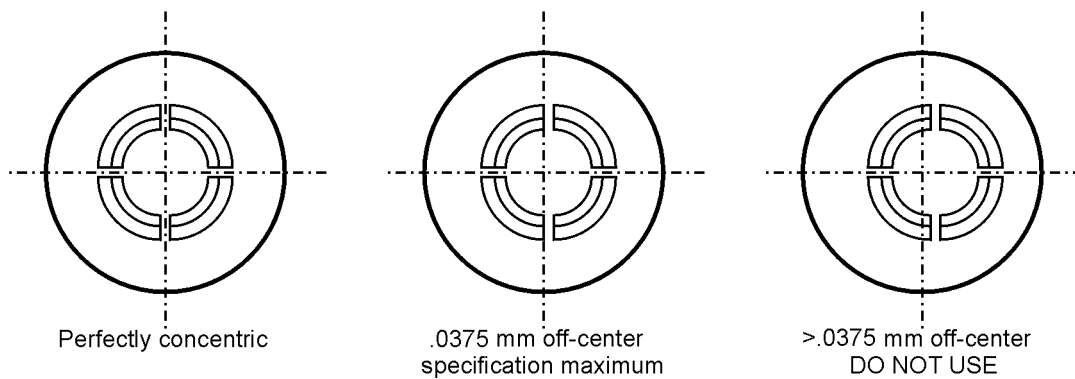

feconnect

Figure 3-4 Concentricity of a Male Connector

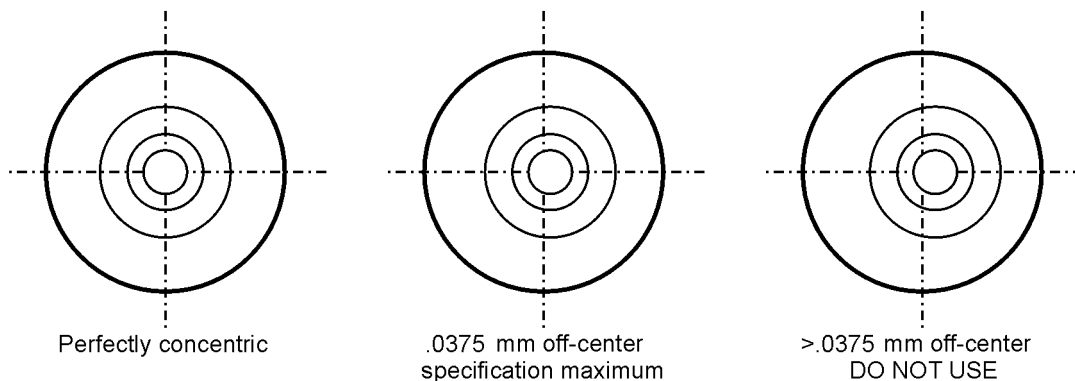

maconnect

Inspect the Mating Plane Surfaces

Flat contact between the connectors at all points on their mating plane surfaces is required for a good connection. See Figure 2-1 on page 2-3. Look especially for deep scratches or dents, and for dirt and metal particles on the connector mating plane surfaces. Also look for signs of damage due to excessive or uneven wear or misalignment.

Light burnishing of the mating plane surfaces is normal, and is evident as light scratches or shallow circular marks distributed more or less uniformly over the mating plane surface. Other small defects and cosmetic imperfections are also normal. None of these affect electrical or mechanical performance.

If a connector shows deep scratches or dents, particles clinging to the mating plane surfaces, or uneven wear, clean and inspect it again. Devices with damaged connectors should be discarded. Determine the cause of damage before connecting a new, undamaged connector in the same configuration.

Inspect Female Connectors

Pay special attention to the contact fingers in the female center conductor. These can be bent or broken, and damage to them is not always easy to see. A connector with damaged contact fingers will negatively affect electrical performance and must be replaced.

| | |
|-------------|---|
| NOTE | Inspection is particularly important when mating nonprecision to precision devices. |
|-------------|---|

Cleaning Connectors

Clean connectors are essential for ensuring the integrity of RF and microwave coaxial connections.

1. Use Compressed Air or Nitrogen

WARNING Always use protective eyewear when using compressed air or nitrogen.

Use compressed air (or nitrogen) to loosen particles on the connector mating plane surfaces.

You can use any source of clean, dry, low-pressure compressed air or nitrogen that has an effective oil-vapor filter and liquid condensation trap placed just before the outlet hose.

Ground the hose nozzle to prevent electrostatic discharge, and set the air pressure to less than 414 kPa (60 psi) to control the velocity of the air stream. High-velocity streams of compressed air can cause electrostatic effects when directed into a connector. These electrostatic effects can damage the device. Refer to “Electrostatic Discharge” earlier in this chapter for additional information.

2. Clean the Connector Threads

WARNING Keep isopropyl alcohol away from heat, sparks, and flame. Store in a tightly closed container. It is extremely flammable. In case of fire, use alcohol foam, dry chemical, or carbon dioxide; water may be ineffective.

Use isopropyl alcohol with adequate ventilation and avoid contact with eyes, skin, and clothing. It causes skin irritation, may cause eye damage, and is harmful if swallowed or inhaled. It may be harmful if absorbed through the skin. Wash thoroughly after handling.

In case of spill, soak up with sand or earth. Flush spill area with water.

Dispose of isopropyl alcohol in accordance with all applicable federal, state, and local environmental regulations.

Use a lint-free swab or cleaning cloth moistened with isopropyl alcohol to remove any dirt or stubborn contaminants on a connector that cannot be removed with compressed air or nitrogen. Refer to Table 6-3 on page 6-8 for part numbers for isopropyl alcohol and cleaning swabs.

- a. Apply a small amount of isopropyl alcohol to a lint-free cleaning swab.
- b. Clean the connector threads.
- c. Let the alcohol evaporate, then blow the threads dry with a gentle stream of clean, low-pressure compressed air or nitrogen. Always completely dry a connector before you reassemble or use it.

3. Clean the Mating Plane Surfaces

- a. Apply a small amount of isopropyl alcohol to a lint-free cleaning swab.
- b. Clean the center and outer conductor mating plane surfaces. Refer to Figure 2-1 on page 2-3. When cleaning a female connector, avoid snagging the swab on the center conductor contact fingers by using short strokes.
- c. Let the alcohol evaporate, then blow the connector dry with a gentle stream of clean, low-pressure compressed air or nitrogen. Always completely dry a connector before you reassemble or use it.

4. Reinspect

Inspect the connector again to make sure that no particles or residue are present.

Gaging Connectors

The gages available from Agilent Technologies are intended for preventive maintenance and troubleshooting purposes only. (See Table 6-3 on page 6-8 for part number information.) They are effective in detecting excessive center conductor protrusion or recession, and conductor damage on DUTs, test accessories, and the calibration kit devices. *Do not use the gages for precise pin depth measurements.*

Connector Gage Accuracy

The connector gages are only capable of performing coarse measurements. They do not provide the degree of accuracy necessary to precisely measure the pin depth of the kit devices. This is partially due to the repeatability uncertainties that are associated with the measurement. Only the factory—through special gaging processes and electrical testing—can accurately verify the mechanical characteristics of the devices.

With proper technique, however, the gages are useful in detecting gross pin depth errors on device connectors. To achieve maximum accuracy, random errors must be reduced by taking the average of at least three measurements having different gage orientations on the connector. Even the resultant average can be in error by as much as ± 0.0001 inch due to systematic (biasing) errors usually resulting from worn gages and gage masters. The information in Table 2-2 on page 2-4 assumes new gages and gage masters. Therefore, these systematic errors were not included in the uncertainty analysis. As the gages undergo more use, the systematic errors can become more significant in the accuracy of the measurement.

The measurement uncertainties (see Table 2-2 on page 2-4) are primarily a function of the assembly materials and design, and the unique interaction each device type has with the gage. Therefore, these uncertainties can vary among the different devices. For example, note the difference between the uncertainties of the opens and shorts in Table 2-2.

The observed pin depth limits in Table 2-2 add these uncertainties to the typical factory pin depth values to provide practical limits that can be referenced when using the gages. See “Pin Depth” on page 2-3. Refer to “85058B (Standard) Kit Contents” on page 1-4 and “85058E (Economy) Kit Contents” on page 1-6 for more information on the design of the calibration devices in this kit.

NOTE When measuring pin depth, the measured value (resultant average of three or more measurements) contains measurement uncertainty and is not necessarily the true value. Always compare the measured value with the *observed* pin depth limits (which account for measurement uncertainties) in Table 2-2 on page 2-4 to evaluate the condition of device connectors.

When to Gage Connectors

Gage a connector at the following times:

- Prior to using a device for the first time: record the pin depth measurement so that it can be compared with future readings. (It will serve as a good troubleshooting tool when you suspect damage may have occurred to the device.)
- If either visual inspection or electrical performance suggests that the connector interface may be out of typical range (due to wear or damage, for example).
- If a calibration device is used by someone else or on another system or piece of equipment.
- Initially after every 100 connections, and after that as often as experience indicates.

Gaging Procedures

Gaging Male 1.85 mm Connectors

NOTE Always hold a connector gage by the gage barrel, below the dial indicator. This gives the best stability, and improves measurement accuracy. (Cradling the gage in your hand or holding it by the dial applies stress to the gage plunger mechanism through the dial indicator housing.)

1. Select the proper gage for your connector. The 1.85 mm connectors are gaged with the same gages and in the same way as precision 2.4 mm connectors. Refer to Table 6-3 on page 6-8 for gage part numbers.
2. Inspect and clean the gage, gage master, and device to be gaged. Refer to “Visual Inspection” and “Cleaning Connectors” earlier in this chapter.
3. Zero the connector gage (refer to Figure 3-5):
 - a. While holding the gage by the barrel, and without turning the gage or the device, screw the male gage master connecting nut onto the male gage, just until you meet resistance. Connect the nut finger tight. Do not overtighten.
 - b. Use the torque wrench recommended for use with the kit to tighten the connecting nut to 90 N-cm (8 in-lb). Refer to “Connections” on page 3-14 for more information.
 - c. As you watch the gage pointer, gently tap the barrel of the gage to settle the reading. The gage pointer should line up exactly with the zero mark on the gage. If not, adjust the zero set knob until the gage pointer lines up exactly with zero.
 - d. Remove the gage master.
4. Gage the device connector (refer to Figure 3-5):
 - a. While holding the gage by the barrel, and without turning the gage or the device, screw the connecting nut of the male device being measured onto the male gage, just until you meet resistance. Connect the nut finger-tight. Do not overtighten.
 - b. Use the torque wrench recommended for use with the kit to tighten the connecting nut to 90 N-cm (8 in-lb). Refer to “Connections” on page 3-14 for more information.
 - c. Gently tap the barrel of the gage with your finger to settle the gage reading.
 - d. Read the gage indicator dial. Read *only* the black \pm signs; *not* the red \pm signs.

For maximum accuracy, measure the connector a minimum of three times and take an average of the readings. After each measurement, rotate the gage a quarter-turn to reduce measurement variations that result from the gage or the connector face not being exactly perpendicular to the center axis.
 - e. Compare the average reading with the observed pin depth limits in Table 2-2 on page 2-4.

Figure 3-5 Gaging Male 1.85 mm Connectors

Zero the Connector Gage

- Screw the male gage master connecting nut onto the male gage.
- Torque the connecting nut.
- Gently tap the gage barrel to settle the reading.
- Using the zero set knob, adjust the gage pointer to line up exactly with the zero mark.
- Remove the gage master.

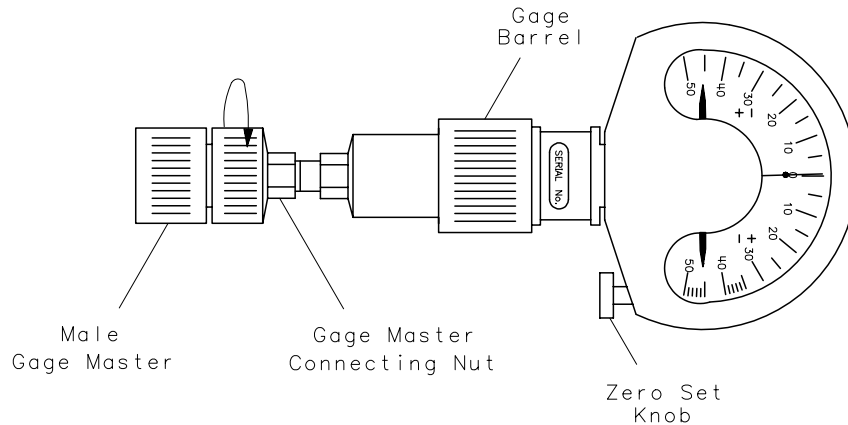

Gage the Device Connector

- Screw the male device connecting nut onto the male gage.
- Torque the connecting nut.
- Gently tap the gage barrel to settle the reading.
- Read recession or protrusion from the gage.
- Remove the device.

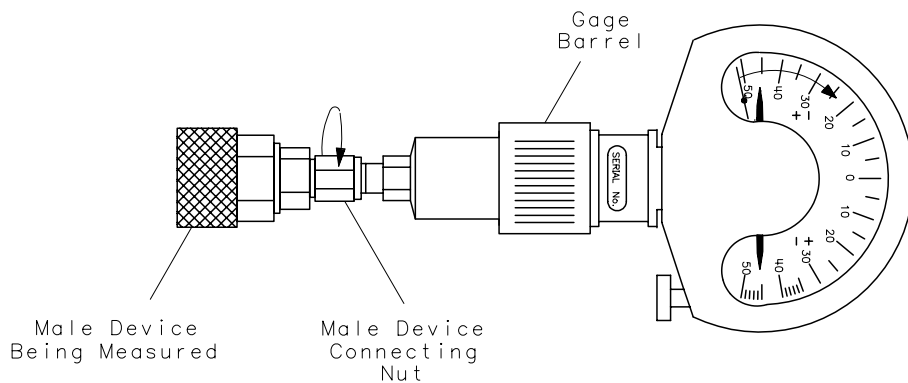

wj615d.

Gaging Female 1.85 mm Connectors

NOTE Always hold a connector gage by the gage barrel, below the dial indicator. This gives the best stability, and improves measurement accuracy. (Cradling the gage in your hand or holding it by the dial applies stress to the gage plunger mechanism through the dial indicator housing.)

1. Select the proper gage for your connector. The 1.85 mm connectors are gaged with the same gages and in the same way as precision 2.4 mm connectors. Refer to Table 6-3 on page 6-8 for gage part numbers.
2. Inspect and clean the gage, gage master, and device to be gaged. Refer to “Visual Inspection” and “Cleaning Connectors” earlier in this chapter.
3. Zero the connector gage (refer to Figure 3-6):
 - a. While holding the gage by the barrel, and without turning the gage or the device, screw the female gage connecting nut onto the female gage master, just until you meet resistance. Connect the nut finger-tight. Do not overtighten.
 - b. Use the torque wrench recommended for use with the kit to tighten the connecting nut to 90 N-cm (8 in-lb). Refer to “Connections” on page 3-14 for more information.
 - c. As you watch the gage pointer, gently tap the barrel of the gage to settle the reading.
The gage pointer should line up exactly with the zero mark on the gage. If not, adjust the zero set knob until the gage pointer lines up exactly with zero.
 - d. Remove the gage master.
4. Gage the device connector (refer to Figure 3-6):
 - a. While holding the gage by the barrel, and without turning the gage or the device, screw the female gage connecting nut onto the female device being measured, just until you meet resistance. Connect the nut finger-tight. Do not overtighten.
 - b. Use the torque wrench recommended for use with the kit to tighten the connecting nut to 90 N-cm (8 in-lb). Refer to “Connections” on page 3-14 for more information.
 - c. Gently tap the barrel of the gage with your finger to settle the gage reading.
 - d. Read the gage indicator dial. Read *only* the black \pm signs; *not* the red \pm signs.
For maximum accuracy, measure the connector a minimum of three times and take an average of the readings. Use different orientations of the gage within the connector. After each measurement, rotate the gage a quarter-turn to reduce measurement variations that result from the gage or the connector face not being exactly perpendicular to the center axis.
 - e. Compare the average reading with the observed pin depth limits in “Pin Depth Limit” on page 2-4.

Figure 3-6 Gaging Female 1.85 mm Connectors

Zero the Connector Gage

- Screw the female gage connecting nut onto the female gage master.
- Torque the connecting nut.
- Gently tap the gage barrel to settle the reading.
- Using the zero set knob, adjust the gage pointer to line up exactly with the zero mark.
- Remove the gage master.

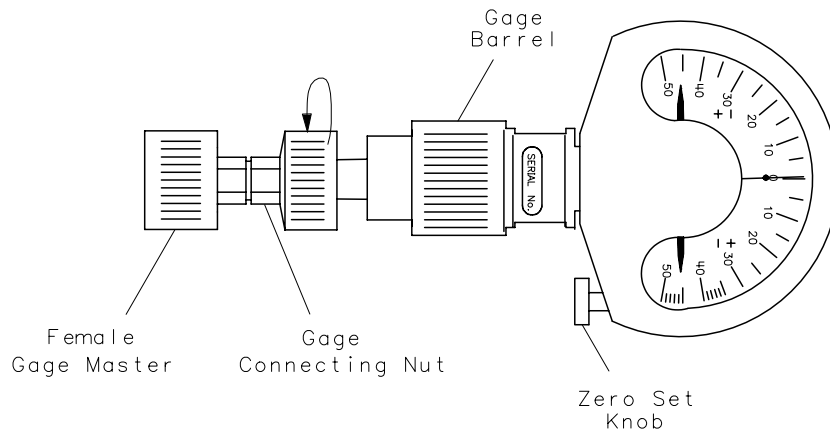

Gage the Device Connector

- Screw the female gage connecting nut onto the female device.
- Torque the connecting nut.
- Gently tap the gage barrel to settle the reading.
- Read recession or protrusion from the gage.
- Remove the device.

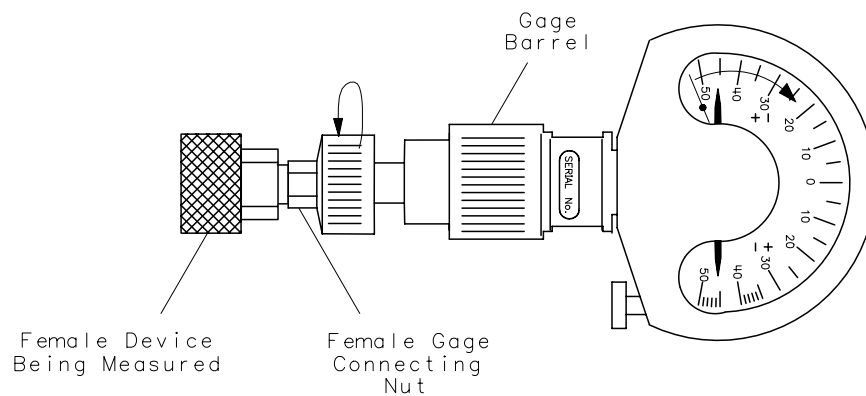

wj616d

Connections

Good connections require a skilled operator. *The most common cause of measurement error is bad connections.* The following procedures illustrate how to make good connections.

How to Make a Connection

Preliminary Connection

1. Ground yourself and all devices. Wear a grounded wrist strap and work on a grounded, conductive table mat. Refer to “Electrostatic Discharge” on page 3-2 for ESD precautions.
2. Visually inspect the connectors. Refer to “Visual Inspection” on page 3-3.
3. If necessary, clean the connectors. Refer to “Cleaning Connectors” on page 3-6.
4. Use a connector gage to verify that all center conductors are within the observed pin depth values in Table 2-2 on page 2-4. Refer to “Gaging Connectors” on page 3-8.
5. Carefully align the connectors. The male connector center pin must slip concentrically into the contact finger of the female connector.
6. Push the connectors straight together.

CAUTION Do not turn the device body. Only turn the connector nut. Damage to the center conductor and outer conductor can occur if the device body is twisted.

Do not twist or screw the connectors together. As the center conductors mate, there is usually a slight resistance.

7. The preliminary connection is tight enough when the mating plane surfaces make uniform, light contact. Do not overtighten this connection.

A connection in which the outer conductors make gentle contact at all points on both mating surfaces is sufficient. Very light finger pressure is enough to accomplish this.

8. Make sure the connectors are properly supported. Relieve any side pressure on the connection from long or heavy devices or cables.

Final Connection Using a Torque Wrench

1. Use a torque wrench to make a final connection. Table 3-1 provides information about the torque wrench recommended for use with this calibration kit. A torque wrench is *not* included in the 85058E (Economy) calibration kit. Refer to Table 6-3 on page 6-8 for part number and ordering information.

Table 3-1 Torque Wrench Information

| Connector Type | Torque Setting | Torque Tolerance |
|----------------|-------------------|----------------------|
| 1.85 mm | 90 N-cm (8 in-lb) | ±9 N-cm (±0.8 in-lb) |

Using a torque wrench guarantees that the connection is not too tight, preventing possible connector damage. It also guarantees that all connections are equally tight each time.

2. Prevent the rotation of anything other than the connector nut that you are tightening. It may be possible to do this by hand if one of the connectors is fixed (as on a test port). In all situations, however, it is recommended that you use an open-end wrench to keep the body of the device from turning. Refer to Chapter 6 for part number and ordering information.
3. Position both wrenches within 90 degrees of each other before applying force. See Figure 3-7. Wrenches opposing each other (greater than 90 degrees apart) will cause a lifting action which can misalign and stress the connections of the devices involved. This is especially true when several devices are connected together.

Figure 3-7 Wrench Positions

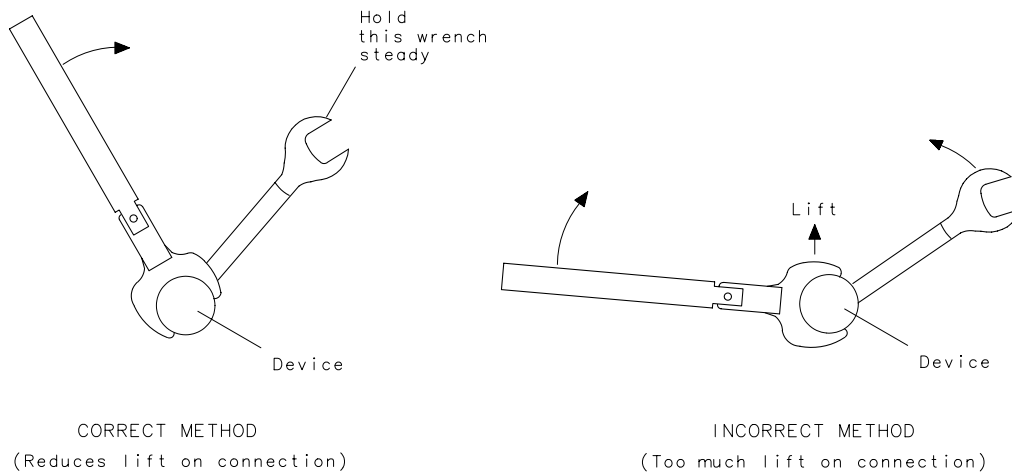

wj56f

4. Hold the torque wrench lightly, at the end of the handle only (beyond the groove). See Figure 3-8.

Figure 3-8 Using the Torque Wrench

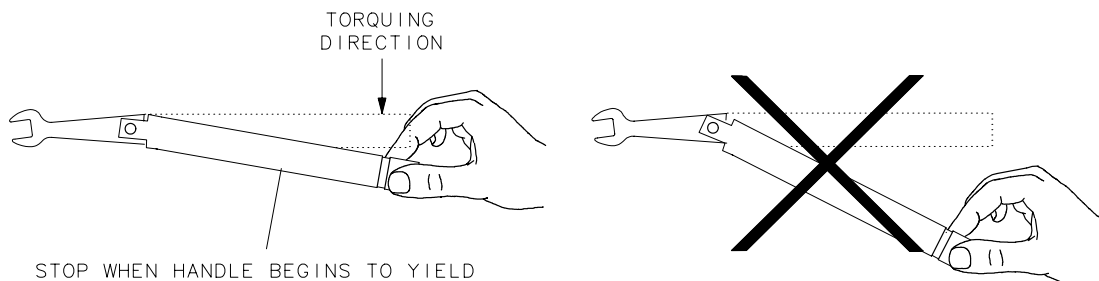

wj68d

Handling and Storage

5. Apply downward force perpendicular to the wrench handle. See Figure 3-8. This applies torque to the connection through the wrench.

Do not hold the wrench so tightly that you push the handle straight down along its length rather than pivoting it, otherwise you apply an unknown amount of torque.

6. Tighten the connection just to the torque wrench break point. The wrench handle gives way at its internal pivot point. See Figure 3-8. Do not tighten the connection further.

CAUTION You don't have to fully break the handle of the torque wrench to reach the specified torque; doing so can cause the handle to kick back and loosen the connection. Any give at all in the handle is sufficient torque.

Do not pivot the wrench handle on your thumb or other fingers, otherwise you apply an unknown amount of torque to the connection when the wrench reaches its break point.

Do not twist the head of the wrench relative to the outer conductor mating plane. If you do, you apply more than the recommended torque.

How to Separate a Connection

To avoid lateral (bending) force on the connector mating plane surfaces, always support the devices and connections.

CAUTION Turn the connector nut, *not* the device body. Major damage to the center conductor can occur if the device body is twisted.

1. Use an open-end wrench to prevent the device body from turning.
2. Use another open-end wrench to loosen the connector nut.
3. Complete the separation by hand, turning only the connector nut.
4. Pull the connectors straight apart without twisting, rocking, or bending either of the connectors.

Handling and Storage

- Install the protective end caps and store the calibration devices in the foam-lined storage case when not in use.
- Never store connectors loose in a box, desk, or bench drawer. This is the most common cause of connector damage during storage.
- Keep connectors clean.
- Do not touch mating plane surfaces. Natural skin oils and microscopic particles of dirt are easily transferred to a connector interface and are very difficult to remove.
- Do not set connectors contact-end down on a hard surface. The plating and the mating plane surfaces can be damaged if the interface comes in contact with any hard surface.

4 Performance Verification

Introduction

The performance of your calibration kit can only be verified by returning the kit to Agilent Technologies for recertification. The equipment required to verify the specifications of the devices in the kit has been specially manufactured and is not commercially available.

How Agilent Verifies the Devices in This Kit

Agilent verifies the specifications of these devices as follows:

1. The residual microwave error terms of the test system are verified with precision airlines and shorts that are directly traced to NIST (National Institute of Standards and Technology). The airline and short characteristics are developed from mechanical measurements. The mechanical measurements and material properties are carefully modeled to give very accurate electrical representation. The mechanical measurements are then traced to NIST through various plug and ring gages and other mechanical measurements.
2. Each calibration device is electrically tested on this system. For the initial (before sale) testing of the calibration devices, Agilent includes the test measurement uncertainty as a guardband to guarantee each device meets the published specification. For recertifications (after sale), no guardband is used and the measured data is compared directly with the specification to determine the pass or fail status. The measurement uncertainty for each device is, however, recorded in the calibration report that accompanies recertified kits.

These two steps establish a traceable link to NIST for Agilent to the extent allowed by the institute's calibration facility. The specifications data provided for the devices in this kit is traceable to NIST through Agilent Technologies.

Recertification

The following will be provided with a recertified kit:

- a new calibration sticker affixed to the case
- a certificate of calibration
- a calibration report for each device in the kit listing measured values, specifications, and uncertainties

NOTE A list of NIST traceable numbers may be purchased upon request to be included in the calibration report.

Agilent Technologies offers a *Standard* calibration for the recertification of this kit. For more information, contact Agilent Technologies. See Table 5-1 on page 5-3.

How Often to Recertify

The suggested initial interval for recertification is 12 months or sooner. The actual need for recertification depends on the use of the kit. After reviewing the results of the initial recertification, you may establish a different recertification interval that reflects the usage and wear of the kit.

NOTE The recertification interval should begin on the date the kit is *first used* after the recertification date.

Where to Send a Kit for Recertification

Contact Agilent Technologies for information on where to send your kit for recertification. See Table 5-1 on page 5-3.

When you return the kit, complete and attach a service tag. Refer to "Returning a Kit or Device to Agilent," on page 5-3 for details.

5 Troubleshooting

Troubleshooting Process

If you suspect a bad calibration, or if your network analyzer does not pass performance verification, follow the steps in Figure 5-1.

Figure 5-1 Troubleshooting Flowchart

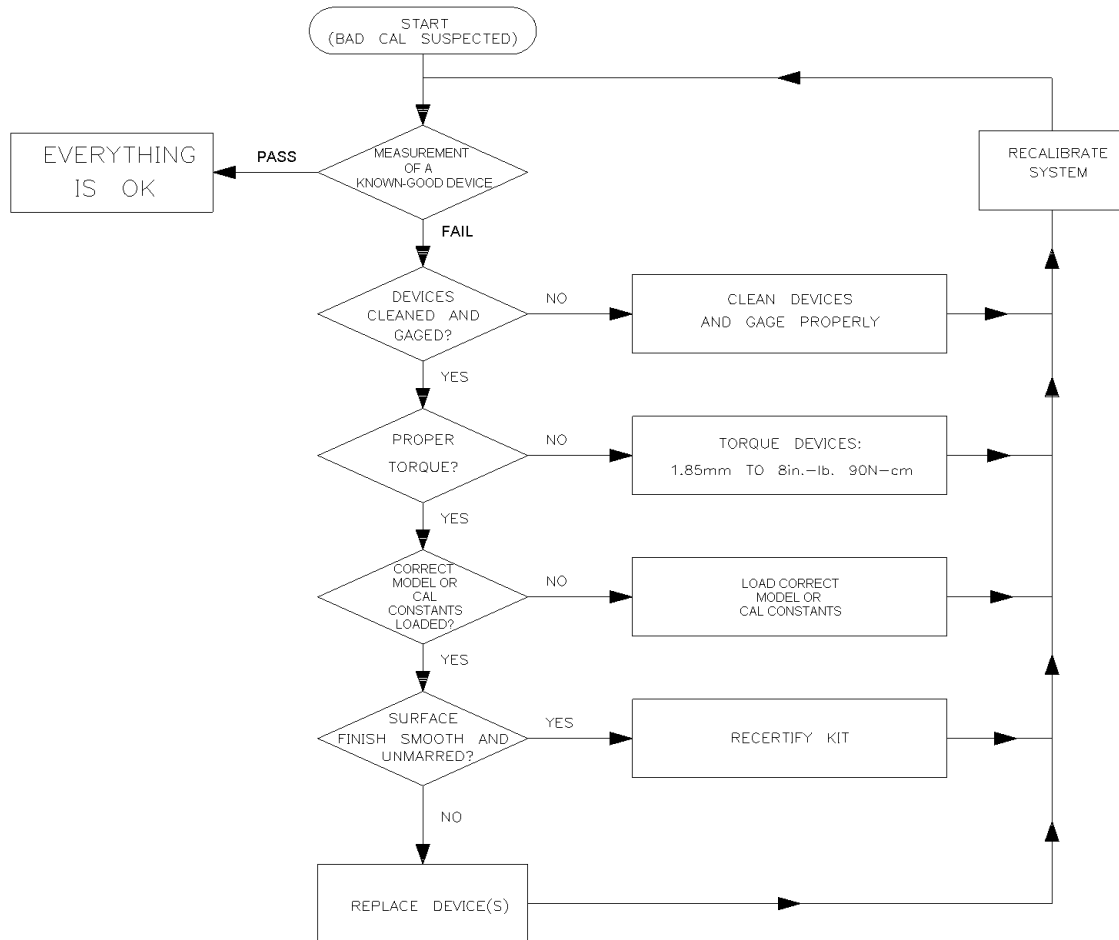

Returning a Kit or Device to Agilent

If your kit or device requires service, contact the Agilent Technologies office nearest you for information on where to send it. See Table 5-1. Include a service tag (located near the end of this manual) on which you provide the following information:

- your company name and address
- a technical contact person within your company, and the person's complete phone number
- the model number and serial number of the kit
- the part number and serial number of each device
- the type of service required
- a *detailed* description of the problem and how the device was being used when the problem occurred (such as calibration or measurement)

By internet, phone, or fax, get assistance with all your test and measurement needs.

Table 5-1 Contacting Agilent

Online assistance: www.agilent.com/find/assist

Americas

| | | | |
|---|--|---|---|
| Brazil (tel) (+55) 11 4197 3600 (fax) (+55) 11 4197 3800 | Canada (tel) 877 894 4414 (fax) (+1) 905 282-6495 | Mexico (tel) (+52) 55 5081 9469 (alt) 01800 5064 800 (fax) (+52) 55 5081 9467 | United States (tel) 800 829 4444 (alt) (+1) 303 662 3998 (fax) 800 829 4433 |
|---|--|---|---|

Asia Pacific and Japan

| | | | |
|---|---|--|--|
| Australia (tel) 1800 629 485 (alt) 1800 143 243 (fax) 1800 142 134 | China (tel) 800 810 0189 (alt) (+86) 10800 650 0021 (fax) 800 820 2816 | Hong Kong (tel) 800 930 871 (alt) (+852) 3197 7889 (fax) (+852) 2 506 9233 | India (tel) 1600 112 929 (fax) 000800 650 1101 |
| Japan (tel) 0120 421 345 (alt) (+81) 426 56 7832 (fax) 0120 421 678 | Malaysia (tel) 1800 888 848 (alt) 1800 828 848 (fax) 1800 801 664 | Singapore (tel) 1800 375 8100 (alt) (+65) 6 375 8100 (fax) (+65) 6836 0252 | South Korea (tel) 080 769 0800 (alt) (+82) 2 2004 5004 (fax) (+82) 2 2004 5115 |
| Taiwan (tel) 0800 047 866 (alt) 00801 651 317 (fax) 0800 286 331 | Thailand (tel) 1800 226 008 (alt) (+66) 2 268 1345 (fax) (+66) 2 661 3714 | | |

Europe

| | | | |
|---|---|---|--|
| Austria (tel) 0820 87 44 11* (fax) 0820 87 44 22 | Belgium (tel) (+32) (0)2 404 9340 (alt) (+32) (0)2 404 9000 (fax) (+32) (0)2 404 9395 | Denmark (tel) (+45) 7013 1515 (alt) (+45) 7013 7313 (fax) (+45) 7013 1555 | Finland (tel) (+358) 10 855 2100 (fax) (+358) 10 855 2923 |
|---|---|---|--|

Table 5-1 Contacting Agilent

| | | | |
|--|---|--|---|
| <p>France <i>(tel)</i> 0825 010 700* <i>(alt)</i> (+33) (0)1 6453 5623 <i>(fax)</i> 0825 010 701*</p> | <p>Germany <i>(tel)</i> 01805 24 6333* <i>(alt)</i> 01805 24 6330* <i>(fax)</i> 01805 24 6336*</p> | <p>Ireland <i>(tel)</i> (+353) (0)1 890 924 204 <i>(alt)</i> (+353) (0)1 890 924 206 <i>(fax)</i> (+353) (0)1 890 924 024</p> | <p>Israel <i>(tel)</i> (+972) 3 9288 500 <i>(fax)</i> (+972) 3 9288 501</p> |
| <p>Italy <i>(tel)</i> (+39) (0)2 9260 8484 <i>(fax)</i> (+39) (0)2 9544 1175</p> | <p>Luxemburg <i>(tel)</i> (+32) (0)2 404 9340 <i>(alt)</i> (+32) (0)2 404 9000 <i>(fax)</i> (+32) (0)2 404 9395</p> | <p>Netherlands <i>(tel)</i> (+31) (0)20 547 2111 <i>(alt)</i> (+31) (0)20 547 2000 <i>(fax)</i> (+31) (0)20 547 2190</p> | <p>Russia <i>(tel)</i> (+7) 095 797 3963 <i>(alt)</i> (+7) 095 797 3900 <i>(fax)</i> (+7) 095 797 3901</p> |
| <p>Spain <i>(tel)</i> (+34) 91 631 3300 <i>(alt)</i> (+34) 91 631 3000 <i>(fax)</i> (+34) 91 631 3301</p> | <p>Sweden <i>(tel)</i> 0200 88 22 55* <i>(alt)</i> (+46) (0)8 5064 8686 <i>(fax)</i> 020 120 2266*</p> | <p>Switzerland (French) <i>(tel)</i> 0800 80 5353 opt. 2* <i>(alt)</i> (+33) (0)1 6453 5623 <i>(fax)</i> (+41) (0)22 567 5313</p> | <p>Switzerland (German) <i>(tel)</i> 0800 80 5353 opt. 1* <i>(alt)</i> (+49) (0)7031 464 6333 <i>(fax)</i> (+41) (0)1 272 7373</p> |
| <p>Switzerland (Italian) <i>(tel)</i> 0800 80 5353 opt. 3* <i>(alt)</i> (+39) (0)2 9260 8484 <i>(fax)</i> (+41) (0)22 567 5314</p> | <p>United Kingdom <i>(tel)</i> (+44) (0)7004 666666 <i>(alt)</i> (+44) (0)7004 123123 <i>(fax)</i> (+44) (0)7004 444555</p> | | |

(tel) = primary telephone number; *(alt)* = alternate telephone number; *(fax)* = FAX number; * = in country number

6 Replaceable Parts

Introduction

Table 6-1 lists the replacement part numbers for items included in the 85058B (Standard) calibration kit and Figure 6-1 illustrates each of these items.

Table 6-2 lists the replacement part numbers for items included in the 85058B (Economy) calibration kit and Figure 6-2 illustrates each of these items.

Table 6-3 lists the replacement part numbers for items recommended or required for successful operation but not included in the calibration kit.

To order a listed part, note the description, the part number, and the quantity desired. Telephone or send your order to Agilent Technologies. See Table 5-1 on page 5-3.

Table 6-1 Replaceable Parts for the 85058B (Standard) Calibration Kit

| Description | Qty Per Kit | Agilent Part Number |
|--|-------------|--------------------------|
| Calibration Devices (1.85 mm)^{a,b} | | |
| 5.4 mm offset short 1 –m– | 1 | 85058-60101 |
| 6.3 mm offset short 2 –m– | 1 | 85058-60102 |
| 7.12 mm offset short 3 –m– | 1 | 85058-60103 |
| 7.6 mm offset short 4 –m– | 1 | 85058-60104 |
| 5.4 mm offset short 1 –f– | 1 | 85058-60105 |
| 6.3 mm offset short 2 –f– | 1 | 85058-60106 |
| 7.12 mm offset short 3 –f– | 1 | 85058-60107 |
| 7.6 mm offset short 4 –f– | 1 | 85058-60108 |
| Offset open –m– | 1 | 85058-60109 |
| Offset open –f– | 1 | 85058-60110 |
| Lowband load –m– | 1 | 85058-60111 |
| Lowband load –f– | 1 | 85058-60112 |
| Adapters (1.85 mm)^a | | |
| Adapter m–m | 1 | 85058-60113 |
| Adapter f–f | 1 | 85058-60114 |
| Adapter m–f | 1 | 85058-60115 |
| Calibration Kit Storage Case | | |
| Box | 1 | 5180-5304 |
| Foam (top) | 1 | 5180-5542 |
| Foam (bottom) | 1 | 85058-80014 |
| Disk holder | 1 | 5180-8491 |
| Wrenches | | |
| 5/16 in., 90 N–cm (8 in–lb) torque wrench | 1 | 8710-1765 |
| 8 mm open–end wrench | 1 | 8710-2466 |
| Miscellaneous Items | | |
| 2.4 mm female gage set (also used for 1.85 mm) | 1 | 11752-60107 |
| 2.4 mm male gage set (also used for 1.85 mm) | 1 | 11752-60108 |
| User’s and service guide | 1 | 85058-90005 ^c |

Table 6-1 Replaceable Parts for the 85058B (Standard) Calibration Kit

| Description | Qty Per Kit | Agilent Part Number |
|--|-------------|---------------------|
| Calibration definitions disk for the PNA and 8510 Series | 1 | 85058-10003 |
| 10x Magnifying Glass | 1 | 1000-1114 |
| Connector Care Quick Reference Card | 1 | 08510-90360 |
| Protective end caps (male) | as required | 1401-0208 |
| Protective end caps (female) | as required | 1401-0202 |

- a. See “Clarifying the Sex of a Connector” on page 1-20.
- b. Refer to “How to Identify Devices” on page 1-5.
- c. See “Printing Copies of This Document” on page iii.

Figure 6-1 Replaceable Parts for the 85058B (Standard) Calibration Kit

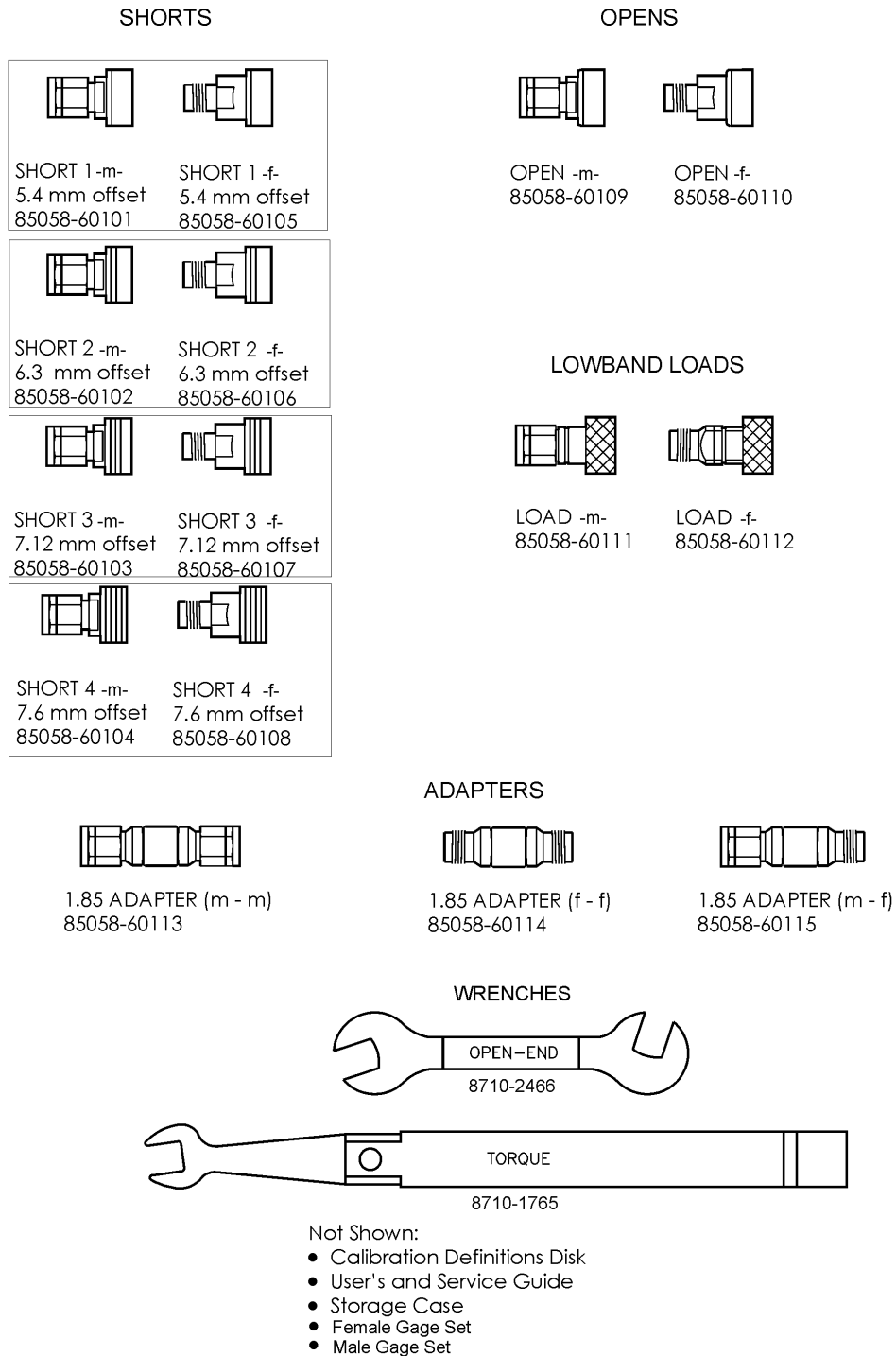
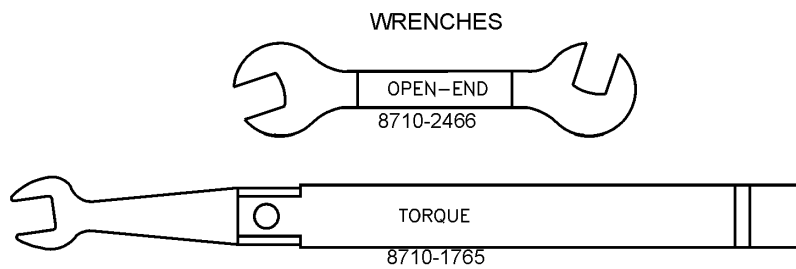
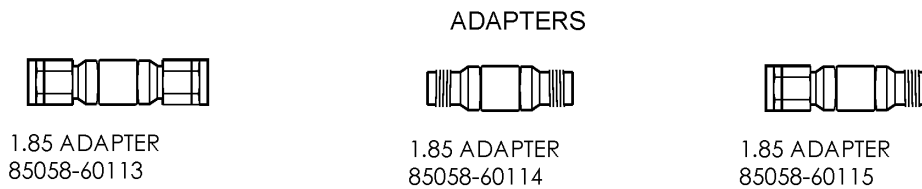
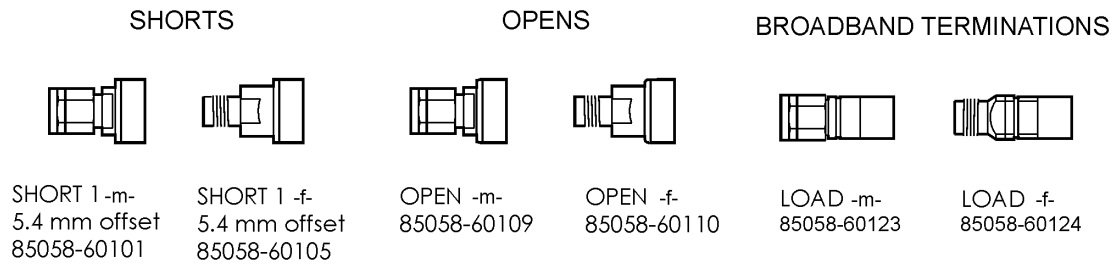

Table 6-2 Replaceable Parts for the 85058E (Economy) Calibration Kit

| Description | Qty Per Kit | Agilent Part Number |
|--|-------------|---------------------|
| Calibration Devices (1.85 mm)^{a,b} | | |
| 5.4 mm offset short –m– | 1 | 85058-60101 |
| 5.4 mm offset short –f– | 1 | 85058-60105 |
| Offset open –m– | 1 | 85058-60109 |
| Offset open –f– | 1 | 85058-60110 |
| Broadband termination –m– | 1 | 85058-60123 |
| Broadband termination –f– | 1 | 85058-60124 |
| Adapters (1.85 mm)^a | | |
| Adapter m–m | 1 | 85058-60113 |
| Adapter f–f | 1 | 85058-60114 |
| Adapter m–f | 1 | 85058-60115 |
| Calibration Kit Storage Case | | |
| Box | 1 | 5180-7862 |
| Foam (top) | 1 | 5180-5544 |
| Foam (bottom) | 1 | 85058-80015 |
| Disk holder | 1 | 5180-8491 |
| Wrenches | | |
| 5/16 in., 90 N–cm (8 in–lb) torque wrench | 1 | 8710-1765 |
| 8 mm open–end wrench | 1 | 8710-2466 |
| Miscellaneous Items | | |
| User’s and service guide | 1 | 85058-90005 |
| Calibration definitions disk for the PNA and 8510 Series | 1 | 85058-11001 |
| Connector Care Quick Reference Card | 1 | 08510-90360 |
| Protective end caps (male) | as required | 1401-0208 |
| Protective end caps (female) | as required | 1401-0202 |

- a. See “Clarifying the Sex of a Connector” on page 1-20.
b. Refer to “How to Identify Devices” on page 1-5.

Figure 6-2 Replaceable Parts for the 85058E (Economy) Calibration Kit



- Not Shown:
- Calibration Definitions Disk
 - User's and Service Guide
 - Storage Case

Table 6-3 Items Not Included in the Calibration Kits

| Description | Qty | Agilent Part Number |
|--|-------|---------------------|
| Adapters^a (50Ω) | | |
| U-band waveguide to 1.85mm –f– coax | 1 | U281A |
| U-band waveguide to 1.85mm –m– coax | 1 | U281B |
| V-band waveguide to 1.85mm –f– coax | 1 | V281A |
| V-band waveguide to 1.85mm –m– coax | 1 | V281B |
| 1mm –m– to 1.85mm –m– | 1 | 11921E |
| 1mm –f– to 1.85mm –f– | 1 | 11921F |
| 1mm –m– to 1.85mm –f– | 1 | 11921G |
| 1mm –f– to 1.85mm –m– | 1 | 11921H |
| Adapter set: 1.85mm –f ^b – to 1.85mm –f– 1.85mm –f ^b – to 1.85mm –m ^b – | 1 set | 85130H |
| Adapter anti-rotation clamp (Two clamps are required for use with the 85130H adapter set.) | 1 | 85130-60016 |
| ESD Protective Devices | | |
| Grounding wrist strap | 1 | 9300-1367 |
| 5 ft grounding cord for wrist strap | 1 | 9300-0980 |
| 2 ft by 4 ft conductive table mat with 15 ft grounding wire | 1 | 9300-0797 |
| ESD heel strap | 1 | 9300-1308 |
| Connector Cleaning Supplies | | |
| Isopropyl alcohol | 30 ml | 8500-5344 |
| Foam tipped cleaning swabs | 100 | 9301-1243 |
| The following items are included in the 85058B (Standard) kit but NOT in the 85058E (Economy) kit. | | |
| 2.4 mm female gage set (also used for 1.85 mm) | 1 | 11752-60107 |
| 2.4 mm male gage set (also used for 1.85 mm) | 1 | 11752-60108 |
| 10x Magnifying Glass | 1 | 1000-1114 |

a. See “Clarifying the Sex of a Connector” on page 1-20.

b. Ruggedized connector.

A Standard Definitions

Version Changes

Class assignments and standard definitions may change as more accurate model and calibration methods are developed. The disk shipped with the kit will contain the most recent version.

Standard Class Assignments

Class assignment organizes calibration standards into a format compatible with the error models used in the measurement calibration. A class or group of classes corresponds to the systematic errors to be removed from the measured network analyzer response. Table A-1 through Table A-6 list the classes of the devices in the calibration kits.

Table A-1 8510 family: 85058B (Standard kit, Polynomial model) Standard Class Assignments

| Calibration Kit Label: 1.85MMBA.2 | | | | | | | | |
|-----------------------------------|--|----|----|---|----|----|---|----------------------|
| Class | A | B | C | D | E | F | G | Standard Class Label |
| S ₁₁ A | 2 | 15 | 14 | 4 | 19 | 18 | | Open/Short |
| S ₁₁ B ^a | 1 | 12 | 3 | 16 | | | | Short |
| S ₁₁ C | 9 | 13 | 17 | | | | | Load/Short |
| S ₂₂ A | 2 | 15 | 14 | 4 | 19 | 18 | | Open/Short |
| S ₂₂ B ^a | 1 | 12 | 3 | 16 | | | | Short |
| S ₂₂ C | 9 | 13 | 17 | | | | | Load/Short |
| Forward Transmission | 11 | | | | | | | Thru |
| Reverse Transmission | 11 | | | | | | | Thru |
| Forward Match | 11 | | | | | | | Thru |
| Reverse Match | 11 | | | | | | | Thru |
| Forward Isolation ^b | 10 | | | | | | | |
| Reverse Isolation | 10 | | | | | | | |
| Frequency Response | 5 | 6 | 7 | 8 | 11 | | | Response |
| TRL Thru or Line | 11 | | | | | | | Thru |
| TRL Reflect | 5 | 7 | | | | | | Short |
| TRL Line or Match | 21 | | | | | | | Match |
| Adapter | 20 | | | | | | | Adapter |
| TRL Option | | | | | | | | |
| Cal Z ₀ : | __ System Z ₀ | | | <input checked="" type="checkbox"/> Line Z ₀ | | | | |
| Set Ref: | <input checked="" type="checkbox"/> Thru | | | __ Reflect | | | | |
| Lowband Frequency: <u>0 Hz</u> | | | | | | | | |

- a. Refer to “Polynomial Model” on page 1-3.
- b. Forward isolation standard is also used for isolation part of response and isolation calibration.

Table A-2 8510 family: 85058E (Economy kit, Polynomial model) Standard Class Assignments

| Calibration Kit Label: 1.85MMEA.2 | | | | | | | | |
|-----------------------------------|--|---|---|---|------------|---|---|----------------------|
| Class | A | B | C | D | E | F | G | Standard Class Label |
| S ₁₁ A | 2 | 4 | | | | | | Open/Short |
| S ₁₁ B | 1 | 3 | | | | | | Short |
| S ₁₁ C | 9 | | | | | | | Load/Short |
| S ₂₂ A | 2 | 4 | | | | | | Open/Short |
| S ₂₂ B | 1 | 3 | | | | | | Short |
| S ₂₂ C | 9 | | | | | | | Load/Short |
| Forward Transmission | 11 | | | | | | | Thru |
| Reverse Transmission | 11 | | | | | | | Thru |
| Forward Match | 11 | | | | | | | Thru |
| Reverse Match | 11 | | | | | | | Thru |
| Forward Isolation ^a | 9 | | | | | | | |
| Reverse Isolation | 9 | | | | | | | |
| Frequency Response | 1 | 2 | 3 | 4 | 11 | | | Response |
| TRL Thru or Line | 11 | | | | | | | Thru |
| TRL Reflect | 1 | | | | | | | Short |
| TRL Line or Match | 14 | | | | | | | Match |
| Adapter | 13 | | | | | | | Adapter |
| TRL Option | | | | | | | | |
| Cal Z ₀ : | __ System Z ₀ | | | <input checked="" type="checkbox"/> Line Z ₀ | | | | |
| Set Ref: | <input checked="" type="checkbox"/> Thru | | | | __ Reflect | | | |
| Lowband Frequency: <u>0</u> Hz | | | | | | | | |

a. Forward isolation standard is also used for isolation part of response and isolation calibration.

Table A-3 PNA family: 85058B (Standard kit, Data-Based model) Standard Class Assignments

| Calibration Kit Label: 85058B Data-Based.ckt | | | | | | | | |
|--|-------------------------|----|----|------------------------------|----|----|---|----------------------|
| Class | A | B | C | D | E | F | G | Standard Class Label |
| S ₁₁ A | 4 | 18 | 19 | 2 | 14 | 15 | | Open/Short |
| S ₁₁ B | 3 | 1 | | | | | | Short |
| S ₁₁ C | 9 | 17 | 24 | 13 | | | | Load/Short |
| S ₂₂ A | 4 | 18 | 19 | 2 | 14 | 15 | | Open/Short |
| S ₂₂ B | 3 | 1 | | | | | | Short |
| S ₂₂ C | 9 | 17 | 24 | 13 | | | | Load/Short |
| Forward Transmission | 11 | | | | | | | Thru |
| Reverse Transmission | 11 | | | | | | | Thru |
| Forward Match | 11 | | | | | | | Thru |
| Reverse Match | 11 | | | | | | | Thru |
| Isolation | | | | | | | | |
| TRL Thru or Line | | | | | | | | Thru |
| TRL Reflect | | | | | | | | Short |
| TRL Line or Match | | | | | | | | Match |
| TRL Option | | | | | | | | |
| Cal Z ₀ : | __System Z ₀ | | | <u>X</u> Line Z ₀ | | | | |
| Set Ref: | __Thru | | | <u>X</u> Reflect | | | | |
| Lowband Frequency: <u>0</u> Hz | | | | | | | | |

Table A-4 PNA Family: 85058BP (Standard kit, Polynomial model) Standard Class Assignments

| Calibration Kit Label: 85058BP Polynomial.ckt | | | | | | | | | |
|---|--------------------------|----|----|------------------------------|----|----|----|---|----------------------|
| Class | A | B | C | D | E | F | G | H | Standard Class Label |
| S ₁₁ A | 4 | 18 | 19 | 8 | 2 | 14 | 15 | 6 | Open/Short |
| S ₁₁ B ^a | 3 | 16 | 7 | 1 | 12 | 5 | | | Short |
| S ₁₁ C | 9 | 17 | 10 | 24 | 13 | 22 | | | Load/Short |
| S ₂₂ A | 4 | 18 | 19 | 8 | 2 | 14 | 15 | 6 | Open/Short |
| S ₂₂ B ^a | 3 | 16 | 7 | 1 | 12 | 5 | | | Short |
| S ₂₂ C | 9 | 17 | 10 | 24 | 13 | 22 | | | Load/Short |
| Forward Transmission | 11 | | | | | | | | Thru |
| Reverse Transmission | 11 | | | | | | | | Thru |
| Forward Match | 11 | | | | | | | | Thru |
| Reverse Match | 11 | | | | | | | | Thru |
| Isolation | | | | | | | | | |
| TRL Thru or Line | | | | | | | | | Thru |
| TRL Reflect | | | | | | | | | Short |
| TRL Line or Match | | | | | | | | | Match |
| TRL Option | | | | | | | | | |
| Cal Z ₀ : | __ System Z ₀ | | | <u>X</u> Line Z ₀ | | | | | |
| Set Ref: | <u>X</u> Thru | | | __ Reflect | | | | | |
| Lowband Frequency: <u>0</u> Hz | | | | | | | | | |

a. Refer to “Polynomial Model” on page 1-3.

Table A-5 PNA Family: 85058E (Standard kit, Data-Based model) Standard Class Assignments

| Calibration Kit Label: 85058E Data-Based.ckt | | | | | | | | |
|--|--------------------------|----|---|------------------------------|---|---|---|----------------------|
| Class | A | B | C | D | E | F | G | Standard Class Label |
| S ₁₁ A | 4 | 2 | | | | | | Open/Short |
| S ₁₁ B | 3 | 1 | | | | | | Short |
| S ₁₁ C | 9 | 24 | | | | | | Load/Short |
| S ₂₂ A | 4 | 2 | | | | | | Open/Short |
| S ₂₂ B | 3 | 1 | | | | | | Short |
| S ₂₂ C | 9 | 24 | | | | | | Load/Short |
| Forward Transmission | 11 | | | | | | | Thru |
| Reverse Transmission | 11 | | | | | | | Thru |
| Forward Match | 11 | | | | | | | Thru |
| Reverse Match | 11 | | | | | | | Thru |
| Isolation | 9 | 24 | | | | | | |
| TRL Thru or Line | | | | | | | | Thru |
| TRL Reflect | | | | | | | | Short |
| TRL Line or Match | | | | | | | | Match |
| TRL Option | | | | | | | | |
| Cal Z ₀ : | __ System Z ₀ | | | <u>X</u> Line Z ₀ | | | | |
| Set Ref: | __ Thru | | | <u>X</u> Reflect | | | | |
| Lowband Frequency: <u>0</u> Hz | | | | | | | | |

Table A-6 PNA Family: 85058EP (Standard kit, Polynomial model) Standard Class Assignments

| Calibration Kit Label: 85058EP Polynomial.ckt | | | | | | | | |
|---|--------------------------|----|---|------------------------------|---|---|---|----------------------|
| Class | A | B | C | D | E | F | G | Standard Class Label |
| S ₁₁ A | 4 | 2 | | | | | | Open/Short |
| S ₁₁ B | 3 | 1 | | | | | | Short |
| S ₁₁ C | 9 | 24 | | | | | | Load/Short |
| S ₂₂ A | 4 | 2 | | | | | | Open/Short |
| S ₂₂ B | 3 | 1 | | | | | | Short |
| S ₂₂ C | 9 | 24 | | | | | | Load/Short |
| Forward Transmission | 11 | | | | | | | Thru |
| Reverse Transmission | 11 | | | | | | | Thru |
| Forward Match | 11 | | | | | | | Thru |
| Reverse Match | 11 | | | | | | | Thru |
| Isolation | 9 | 24 | | | | | | |
| TRL Thru or Line | | | | | | | | Thru |
| TRL Reflect | | | | | | | | Short |
| TRL Line or Match | | | | | | | | Match |
| TRL Option | | | | | | | | |
| Cal Z ₀ : | __ System Z ₀ | | | <u>X</u> Line Z ₀ | | | | |
| Set Ref: | <u>X</u> Thru | | | __ Reflect | | | | |
| Lowband Frequency: <u>0</u> Hz | | | | | | | | |

Blank Forms

The standard class assignments listed in Table A-1 through Table A-6 may be changed to meet your specific requirements. Table A-7 and Table A-8 are provided to record the modified standard class assignments.

Table A-7 8510 Family: Standard Class Assignments Blank Form

| Calibration Kit Label: | | | | | | | | |
|--------------------------------|--------------------------|---|---|------------------------|---|---|---|----------------------|
| Class | A | B | C | D | E | F | G | Standard Class Label |
| S ₁₁ A | | | | | | | | Open |
| S ₁₁ B | | | | | | | | Short |
| S ₁₁ C | | | | | | | | Load |
| S ₂₂ A | | | | | | | | Open |
| S ₂₂ B | | | | | | | | Short |
| S ₂₂ C | | | | | | | | Load |
| Forward Transmission | | | | | | | | Thru |
| Reverse Transmission | | | | | | | | Thru |
| Forward Match | | | | | | | | Thru |
| Reverse Match | | | | | | | | Thru |
| Forward Isolation ^a | | | | | | | | |
| Reverse Isolation | | | | | | | | |
| Frequency Response | | | | | | | | Response |
| TRL Thru | | | | | | | | Thru |
| TRL Reflect | | | | | | | | Short |
| TRL Line | | | | | | | | Load |
| Adapter | | | | | | | | Adapter |
| TRL Option | | | | | | | | |
| Cal Z ₀ : | __ System Z ₀ | | | __ Line Z ₀ | | | | |
| Set Ref: | __ Thru | | | __ Reflect | | | | |
| Lowband Frequency: ____ | | | | | | | | |

- a. Forward isolation standard is also used for isolation part of response and isolation calibration.

Table A-8 PNA Family: Standard Class Assignments Blank Form

| Calibration Kit Label: 1.85 mm | | | | | | | | |
|--------------------------------|--------------------------|---|---|------------------------|---|---|---|----------------------|
| Class | A | B | C | D | E | F | G | Standard Class Label |
| S ₁₁ A | | | | | | | | Open/Short |
| S ₁₁ B | | | | | | | | Short |
| S ₁₁ C | | | | | | | | Load/Short |
| S ₂₂ A | | | | | | | | Open/Short |
| S ₂₂ B | | | | | | | | Short |
| S ₂₂ C | | | | | | | | Load/Short |
| Forward Transmission | | | | | | | | Thru |
| Reverse Transmission | | | | | | | | Thru |
| Forward Match | | | | | | | | Thru |
| Reverse Match | | | | | | | | Thru |
| Isolation | | | | | | | | |
| TRL Thru or Line | | | | | | | | Thru |
| TRL Reflect | | | | | | | | Short |
| TRL Line or Match | | | | | | | | Match |
| TRL Option | | | | | | | | |
| Cal Z ₀ : | __ System Z ₀ | | | __ Line Z ₀ | | | | |
| Set Ref: | __ Thru | | | __ Reflect | | | | |
| Lowband Frequency: __ | | | | | | | | |

Nominal Standard Definitions

Standard definitions provide the definitions needed to mathematically model the electrical characteristics (delay, attenuation, and impedance) of each calibration standard. The nominal values of these definitions are theoretically derived from the physical dimensions and material of each calibration standard, or from actual measured response. These values are used to determine the measurement uncertainties of the network analyzer. The standard definitions in Table A-9 through Table A-14 list typical calibration kit parameters used to specify the mathematical model of each device. This information must be loaded into the network analyzer to perform valid calibrations. Refer to your network analyzer's user's guide or online Help for instructions on loading calibration definitions.

NOTE The values in the standard definitions table are valid *only* over the specified operating temperature range.

Setting the System Impedance

This kit contains only 50 ohm devices. Ensure the system impedance (Z_0) is set to 50 ohms. Refer to your network analyzer's user's guide for instructions on setting system impedance.

Table A-9 8510 family: 85058B (Standard kit, Polynomial model) Standard Definitions

| System $Z_0^a = 50 \Omega$ Disk File Name: CK_185MMBA2 | | | | | | Calibration Kit Label: 1.85MMBA.2 | | | | | | | |
|---|-------|------------------------|---------------------------|-----------------------------|-----------------------------|-----------------------------------|-------------|--------------|--------------|-------------------------------|------|-------------------|-----------------------------|
| Standard ^b | | $C0 \times 10^{-15} F$ | $C1 \times 10^{-27} F/Hz$ | $C2 \times 10^{-36} F/Hz^2$ | $C3 \times 10^{-45} F/Hz^3$ | Fixed or Sliding ^c | Offset | | | Frequency in GHz ^d | | Coax or Waveguide | Standard Label ^e |
| Number | Type | $L0 \times 10^{-12} H$ | $L1 \times 10^{-24} H/Hz$ | $L2 \times 10^{-33} H/Hz^2$ | $L3 \times 10^{-42} H/Hz^3$ | | Delay in ps | $Z_0 \Omega$ | Loss in GΩ/s | Min | Max | | |
| 1 | Short | -0.6715 | 98.949 | -0.8139 | -0.0212 | | 18.012 | 50 | 3.9774 | 0 | 35.5 | Coax | (f) Shrt1 LB ^f |
| 2 | Open | 2.127 | 73.815 | -9.1135 | 0.13886 | | 18.011 | 50 | 3.2762 | 0 | 35.5 | Coax | (f) Open LB |
| 3 | Short | 1.8222 | -934.86 | 64.091 | -1.1161 | | 18.012 | 50 | 3.9664 | 0 | 35.5 | Coax | (m) Shrt1 LB ^f |
| 4 | Open | -7.7748 | 1332.4 | -64.26 | 0.90991 | | 18.015 | 50 | 3.2754 | 0 | 35.5 | Coax | (m) Open LB |
| 5 | Short | 0.9658 | 8.9552 | -0.7884 | 0.0079 | | 18.012 | 50 | 4.0608 | 0 | 999 | Coax | (f) Shrt1 BB |
| 6 | Open | 2.2757 | 0.60959 | -3.9739 | 0.05204 | | 18.011 | 50 | 3.2815 | 0 | 999 | Coax | (f) Open BB |
| 7 | Short | 1.4957 | -323.18 | 11.624 | -0.10939 | | 18.012 | 50 | 4.0812 | 0 | 999 | Coax | (m) Shrt1 BB |
| 8 | Open | -3.5342 | 425.24 | -13.946 | 0.12741 | | 18.001 | 50 | 3.2822 | 0 | 999 | Coax | (m) Open BB |
| 9 | Load | | | | | Fixed | 0 | 50 | 0 | 0 | 35.5 | Coax | 35GHz Load |
| 10 | Load | | | | | Fixed | 0 | 50 | 0 | 0 | 999 | Coax | BB Load |
| 11 | Thru | | | | | | 0 | 50 | 0 | 0 | 999 | Coax | Thru |
| 12 | Short | -26.329 | 1436.9 | -24.863 | 0.1393 | | 18.012 | 50 | 4.0087 | 34.9 | 999 | Coax | (f) Shrt1 HB ^f |
| 13 | Short | 5.2837 | -255.25 | 4.4398 | -0.0248 | | 21.015 | 50 | 3.9424 | 34.9 | 999 | Coax | (f) Shrt2 |
| 14 | Short | -18.399 | 854.22 | -12.502 | 0.0595 | | 23.75 | 50 | 3.9568 | 45 | 999 | Coax | (f) Shrt3 |
| 15 | Short | 31.176 | -1738.2 | 32.421 | -0.1988 | | 25.351 | 50 | 3.8911 | 34.9 | 55 | Coax | (f) Shrt4 |
| 16 | Short | 81.443 | -5397.5 | 114.29 | -0.77746 | | 18.012 | 50 | 4.0306 | 34.9 | 999 | Coax | (m) Shrt1 HB ^f |
| 17 | Short | -168.11 | 10000 | -195.63 | 1.2477 | | 21.015 | 50 | 3.9661 | 34.9 | 999 | Coax | (m) Shrt2 |
| 18 | Short | -85.542 | 5237.9 | -105.29 | 0.68943 | | 23.75 | 50 | 3.9432 | 45 | 999 | Coax | (m) Shrt3 |
| 19 | Short | 83.336 | -4925.8 | 95.83 | -0.61258 | | 25.351 | 50 | 3.8798 | 34.9 | 55 | Coax | (m) Shrt4 |

**Table A-9 (Continued) 8510 family: 85058B (Standard kit, Polynomial model)
Standard Definitions**

| System $Z_0^a = 50 \Omega$ | | Calibration Kit Label: 1.85MMBA.2 | | | | | | | | | | | |
|-----------------------------|------|-----------------------------------|---------------------------|-----------------------------|-----------------------------|-------------------------------|-------------|--------------|--------------|-------------------------------|-----|-------------------|-----------------------------|
| Disk File Name: CK_185MMBA2 | | | | | | | | | | | | | |
| Standard ^b | | $C0 \times 10^{-15} F$ | $C1 \times 10^{-27} F/Hz$ | $C2 \times 10^{-36} F/Hz^2$ | $C3 \times 10^{-45} F/Hz^3$ | Fixed or Sliding ^c | Offset | | | Frequency in GHz ^d | | Coax or Waveguide | Standard Label ^e |
| Number | Type | $L0 \times 10^{-12} H$ | $L1 \times 10^{-24} H/Hz$ | $L2 \times 10^{-33} H/Hz^2$ | $L3 \times 10^{-42} H/Hz^3$ | | Delay in ps | $Z_0 \Omega$ | Loss in GΩ/s | Min | Max | | |
| 20 | Thru | | | | | | 87.418 | 50 | 4 | 0 | 999 | Coax | Adapter |
| 21 | Thru | | | | | Fixed | 1E+12 | 50 | 4 | 0 | 999 | Coax | Load |

- a. Ensure system Z_0 of network analyzer is set to this value.
- b. Open, short, load, delay/thru, or arbitrary impedance.
- c. Load or arbitrary impedance only.
- d. For waveguide, lower frequency is same as F_{CO} .
- e. Refer to "Clarifying the Sex of a Connector" on page 1-20.
- f. Refer to "Polynomial Model" on page 1-3.

Table A-10 8510 family: 85058E (Economy kit, Polynomial Model) Standard Definitions

| System $Z_0^a = 50 \Omega$ | | | | | | | | | | | | | | Calibration Kit Label: 1.85MMEA.2 | |
|-----------------------------|-------|------------------------|---------------------------|-----------------------------|-----------------------------|-------------------------------|-------------|--------------|--------------|-------------------------------|-----|-------------------|-----------------------------|-----------------------------------|--|
| Disk File Name: CK_185MMEA2 | | | | | | | | | | | | | | | |
| Standard ^b | | $C0 \times 10^{-15} F$ | $C1 \times 10^{-27} F/Hz$ | $C2 \times 10^{-36} F/Hz^2$ | $C3 \times 10^{-45} F/Hz^3$ | Fixed or Sliding ^c | Offset | | | Frequency in GHz ^d | | Coax or Waveguide | Standard Label ^e | | |
| Number | Type | $L0 \times 10^{-12} H$ | $L1 \times 10^{-24} H/Hz$ | $L2 \times 10^{-33} H/Hz^2$ | $L3 \times 10^{-42} H/Hz^3$ | | Delay in ps | $Z_0 \Omega$ | Loss in GΩ/s | Min | Max | | | | |
| 1 | Short | 0.9658 | 8.9552 | -0.7884 | 0.0079 | | 18.012 | 50 | 4.0608 | 0 | 999 | Coax | (f) Shrt 1BB | | |
| 2 | Open | 2.2757 | 0.60959 | -3.9739 | 0.05204 | | 18.011 | 50 | 3.2815 | 0 | 999 | Coax | (f) Open BB | | |
| 3 | Short | 1.4957 | -323.18 | 11.624 | -0.10939 | | 18.012 | 50 | 4.0812 | 0 | 999 | Coax | (m) Shrt 1BB | | |
| 4 | Open | -3.5342 | 425.24 | -13.946 | 0.12741 | | 18.001 | 50 | 3.2822 | 0 | 999 | Coax | (m) Open BB | | |
| 5 | | | | | | | | | | | | | | | |
| 6 | | | | | | | | | | | | | | | |
| 7 | | | | | | | | | | | | | | | |
| 8 | | | | | | | | | | | | | | | |
| 9 | Load | | | | | Fixed | 0 | 50 | 0 | 0 | 999 | Coax | Term BB | | |
| 10 | | | | | | | | | | | | | | | |
| 11 | Thru | | | | | | 0 | 50 | 0 | 0 | 999 | Coax | Thru | | |
| 12 | | | | | | | | | | | | | | | |
| 13 | Thru | | | | | | 87.418 | 50 | 4 | 0 | 999 | Coax | Adapter | | |
| 14 | Thru | | | | | Fixed | 1E+12 | 50 | 4 | 0 | 999 | Coax | Load | | |
| 15 | | | | | | | | | | | | | | | |
| 16 | | | | | | | | | | | | | | | |
| 17 | | | | | | | | | | | | | | | |
| 18 | | | | | | | | | | | | | | | |
| 19 | | | | | | | | | | | | | | | |
| 20 | | | | | | | | | | | | | | | |
| 21 | | | | | | | | | | | | | | | |

a. Ensure system Z_0 of network analyzer is set to this value.
 b. Open, short, load, delay/thru, or arbitrary impedance.
 c. Load or arbitrary impedance only.
 d. For waveguide, lower frequency is same as F_{CO} .
 e. Refer to "Clarifying the Sex of a Connector" on page 1-20.

Table A-11 PNA family: 85058B (Standard kit, Data-Based model) Standard Definitions

| System $Z_0^a = 50 \Omega$ | | | Calibration Kit Label: 85058B Data-Based | | | | | | | | | | | |
|--|----------------------------------|-------|---|---------------------------|-----------------------------|-----------------------------|-------------------------------|-----------------|--------------|----------------------------------|--------------|-------|-------------------|-----------------------------|
| Disk File Name: 85058B Data-Based.ckt | | | | | | | Offset | | | Frequency in GHz ^c | | | | |
| Number | Description ^d | Type | $C0 \times 10^{-15} F$ | $C1 \times 10^{-27} F/Hz$ | $C2 \times 10^{-36} F/Hz^2$ | $C3 \times 10^{-48} F/Hz^3$ | Fixed or Sliding ^b | Delay in psec | | | Loss in GΩ/s | | Coax or Waveguide | Standard Label ^e |
| | | | $L0 \times 10^{-12} H$ | $L1 \times 10^{-24} H/Hz$ | $L2 \times 10^{-33} H/Hz^2$ | $L3 \times 10^{-42} H/Hz^3$ | | Delay in psec | $Z_0 \Omega$ | Loss in GΩ/s | Min | Max | | |
| 1 | 1.85 mm male [SHORT 1] | Short | NA ^f | NA ^f | NA ^f | NA ^f | | NA ^f | 50 | NA ^f | 0 | 73 | Coax | Short 1 -m- |
| 2 | 1.85 mm male [OPEN] | Open | NA ^f | NA ^f | NA ^f | NA ^f | | NA ^f | 50 | NA ^f | 0 | 35.5 | Coax | Open LB -m- |
| 3 | 1.85 mm female [SHORT 1] | Short | NA ^f | NA ^f | NA ^f | NA ^f | | NA ^f | 50 | NA ^f | 0 | 73 | Coax | Short 1 -f- |
| 4 | 1.85 mm female [OPEN] | Open | NA ^f | NA ^f | NA ^f | NA ^f | | NA ^f | 50 | NA ^f | 0 | 35.5 | Coax | Open LB -f- |
| 9 | 1.85 mm female lowband [LB LOAD] | Load | NA ^f | NA ^f | NA ^f | NA ^f | Fixed | NA ^f | 50 | NA ^f | 0 | 35.5 | Coax | Lowband -f- |
| 11 | Insertable thru standard | Thru | NA ^f | NA ^f | NA ^f | NA ^f | | 0 | 50 | 0 | 0 | 73 | Coax | Thru |
| 13 | 1.85 mm male [SHORT 2] | Short | NA ^f | NA ^f | NA ^f | NA ^f | | NA ^f | 50 | NA ^f | 34.9 | 73 | Coax | Short 2 -m- |
| 14 | 1.85 mm male [SHORT 3] | Short | NA ^f | NA ^f | NA ^f | NA ^f | | NA ^f | 50 | NA ^f | 44.999 | 73 | Coax | Short 3 -m- |
| 15 | 1.85 mm male [SHORT 4] | Short | NA ^f | NA ^f | NA ^f | NA ^f | | NA ^f | 50 | NA ^f | 34.9 | 55.01 | Coax | Short 4 -m- |
| 17 | 1.85 mm female [SHORT 2] | Short | NA ^f | NA ^f | NA ^f | NA ^f | | NA ^f | 50 | NA ^f | 34.9 | 73 | Coax | Short 2 -f- |
| 18 | 1.85 mm female [SHORT 3] | Short | NA ^f | NA ^f | NA ^f | NA ^f | | NA ^f | 50 | NA ^f | 44.999 | 73 | Coax | Short 3 -f- |
| 19 | 1.85 mm female [SHORT 4] | Short | NA ^f | NA ^f | NA ^f | NA ^f | | NA ^f | 50 | NA ^f | 34.9 | 55.01 | Coax | Short 4 -f- |
| 24 | 1.85 mm male lowband [LB LOAD] | Load | NA ^f | NA ^f | NA ^f | NA ^f | Fixed | NA ^f | 50 | NA ^f | 0 | 35.5 | Coax | Lowband -m- |

- a. Ensure system Z_0 of network analyzer is set to this value.
- b. Load or arbitrary impedance only.
- c. For waveguide, the lower frequency is the same as F_{CO} .
- d. The description text shown in [square brackets] is present on the calibration device.
- e. Refer to "Clarifying the Sex of a Connector" on page 1-20.
- f. The definition for this data-based calibration standard is in a non-editable file in the PNA.

Table A-12 PNA family: 85058BP (Standard kit, Polynomial model) Standard Definitions

| System $Z_0^a = 50 \Omega$ | | Calibration Kit Label: 85058BP Polynomial | | | | | | | | | | | | |
|--|------------------------------------|--|------------------------|---------------------------|-----------------------------|-----------------------------|-------------------------------|---------------|--------------|--------------|-------------------------------|--------|-------------------|-----------------------------|
| Disk File Name: 85058BP Polynomial.ckt | | | | | | | | | | | | | | |
| Number | Description ^b | Type | $C0 \times 10^{-15} F$ | $C1 \times 10^{-27} F/Hz$ | $C2 \times 10^{-36} F/Hz^2$ | $C3 \times 10^{-45} F/Hz^3$ | Fixed or Sliding ^d | Offset | | | Frequency in GHz ^c | | Coax or Waveguide | Standard Label ^e |
| | | | $L0 \times 10^{-12} H$ | $L1 \times 10^{-24} H/Hz$ | $L2 \times 10^{-33} H/Hz^2$ | $L3 \times 10^{-42} H/Hz^3$ | | Delay in psec | $Z_0 \Omega$ | Loss in GΩ/s | Min | Max | | |
| 1 | 1.85 mm male [SHORT 1] | Short | -0.6715 | 98.949 | -0.8139 | -0.0212 | | 18.012 | 50 | 3.9774 | 0 | 35.010 | Coax | Short 1 LB -m- ^f |
| 2 | 1.85 mm male [OPEN] | Open | 2.127 | 73.815 | -9.1135 | 0.13856 | | 18.011 | 50 | 3.2762 | 0 | 35.5 | Coax | Open LB -m- |
| 3 | 1.85 mm female [SHORT 1] | Short | 1.8222 | -934.86 | 64.091 | -1.1161 | | 18.012 | 50 | 3.9664 | 0 | 35.010 | Coax | Short 1 LB -f ^f |
| 4 | 1.85 mm female [OPEN] | Open | -7.7748 | 1332.4 | -64.26 | 0.90991 | | 18.015 | 50 | 3.2754 | 0 | 35.5 | Coax | Open LB -f- |
| 5 | 1.85 mm male [SHORT 1] | Short | 0.9658 | 8.9552 | -0.7884 | 0.0079 | | 18.012 | 50 | 4.0608 | 0 | 999 | Coax | Short 1 BB -m- |
| 6 | 1.85 mm male [OPEN] | Open | 2.2757 | 0.60959 | -3.9739 | 0.05204 | | 18.011 | 50 | 3.2815 | 0 | 999 | Coax | Open BB -m- |
| 7 | 1.85 mm female [SHORT 1] | Short | 1.4957 | -323.18 | 11.624 | -0.10939 | | 18.012 | 50 | 4.0812 | 0 | 999 | Coax | Short 1 BB -f- |
| 8 | 1.85 mm female [OPEN] | Open | -3.5342 | 425.24 | -13.946 | 0.12741 | | 18.001 | 50 | 3.2822 | 0 | 999 | Coax | Open BB -f- |
| 9 | 1.85 mm female lowband [LB LOAD] | Load | | | | | Fixed | 0 | 50 | 0 | 0 | 35.5 | Coax | Lowband -f- |
| 10 | 1.85 mm female broadband [LB LOAD] | Load | | | | | Fixed | 0 | 50 | 0 | 0 | 999 | Coax | Broadband -f- |
| 11 | Insertable thru standard | Thru | | | | | | 0 | 50 | 0 | 0 | 73 | Coax | Thru |
| 12 | 1.85 mm male [SHORT 1] | Short | -26.329 | 1436.9 | -24.863 | 0.1393 | | 18.012 | 50 | 4.0087 | 34.9 | 73 | Coax | Short 1 HB -m- ^f |
| 13 | 1.85 mm male [SHORT 2] | Short | 5.2837 | -255.25 | 4.4398 | -0.0248 | | 21.015 | 50 | 3.9424 | 34.9 | 73 | Coax | Short 2 -m- |
| 14 | 1.85 mm male [SHORT 3] | Short | -18.399 | 854.22 | -12.502 | 0.0595 | | 23.75 | 50 | 3.9568 | 44.999 | 73 | Coax | Short 3 -m- |
| 15 | 1.85 mm male [SHORT 4] | Short | 31.178 | -1738.2 | 32.421 | -0.1988 | | 25.351 | 50 | 3.8911 | 34.9 | 55.01 | Coax | Short 4-m- |
| 16 | 1.85 mm female [SHORT 1] | Short | 81.443 | -5397.5 | 114.29 | -0.77746 | | 18.012 | 50 | 4.0306 | 34.9 | 73 | Coax | Short 1 HB -f ^f |
| 17 | 1.85 mm female [SHORT 2] | Short | -168.11 | 10025 | -195.63 | 1.2477 | | 21.015 | 50 | 3.9661 | 34.9 | 73 | Coax | Short 2 -f- |
| 18 | 1.85 mm female [SHORT 3] | Short | -85.542 | 5237.9 | -105.29 | 0.68943 | | 23.75 | 50 | 3.9432 | 44.999 | 73 | Coax | Short 3 -f- |

**Table A-12 (Continued) PNA family: 85058BP (Standard kit, Polynomial model)
Standard Definitions**

| System $Z_0^a = 50 \Omega$ | | | Calibration Kit Label: 85058BP Polynomial | | | | | | | | | | | |
|--|----------------------------------|-------|--|---------------------------|-----------------------------|-----------------------------|-------------------------------|---------------|--------------|-------------------------------|-------------------------------|-------|-------------------|-----------------------------|
| Disk File Name: 85058BP Polynomial.ckt | | | | | | | Offset | | | Frequency in GHz ^c | | | | |
| Number | Description ^b | Type | $C0 \times 10^{-15} F$ | $C1 \times 10^{-27} F/Hz$ | $C2 \times 10^{-36} F/Hz^2$ | $C3 \times 10^{-45} F/Hz^3$ | Fixed or Sliding ^d | Offset | | | Frequency in GHz ^c | | Coax or Waveguide | Standard Label ^e |
| | | | $L0 \times 10^{-12} H$ | $L1 \times 10^{-24} H/Hz$ | $L2 \times 10^{-33} H/Hz^2$ | $L3 \times 10^{-42} H/Hz^3$ | | Delay in psec | $Z_0 \Omega$ | Loss in GΩ/s | Min | Max | | |
| 19 | 1.85 mm female [SHORT 4] | Short | 83.336 | -4925.8 | 95.83 | -0.61258 | | 25.351 | 50 | 3.8798 | 34.9 | 55.01 | Coax | Short 4 -f- |
| 22 | 1.85 mm male broadband [LB LOAD] | Load | | | | | Fixed | 0 | 50 | 0 | 0 | 999 | Coax | Broadband -m- |
| 24 | 1.85 mm male lowband [LB LOAD] | Load | | | | | Fixed | 0 | 50 | 0 | 0 | 35.5 | Coax | Lowband -m- |

- a. Ensure system Z_0 of network analyzer is set to this value.
- b. The description text shown in [square brackets] is present on the calibration device.
- c. For waveguide, the lower frequency is the same as F_{CO} .
- d. Load or arbitrary impedance only.
- e. Refer to "Clarifying the Sex of a Connector" on page 1-20.
- f. Refer to "Polynomial Model" on page 1-3.

Table A-13 PNA family: 85058E (Economy kit, Data-Based model) Standard Definitions

| System $Z_0^a = 50 \Omega$ | | Calibration Kit Label: 85058E Data-Based | | | | | | | | | | | | |
|---------------------------------------|--------------------------------------|---|--------------------------------|-----------------------------------|-------------------------------------|-------------------------------------|-------------------------------|-----------------|--------------|-----------------|-------------------------------|-----|-------------------|-----------------------------|
| Disk File Name: 85058E Data-Based.ckt | | | | | | | | | | | | | | |
| Number | Description ^c | Type | $C0 \times 10^{-15} \text{ F}$ | $C1 \times 10^{-27} \text{ F/Hz}$ | $C2 \times 10^{-36} \text{ F/Hz}^2$ | $C3 \times 10^{-45} \text{ F/Hz}^3$ | Fixed or Sliding ^d | Offset | | | Frequency in GHz ^b | | Coax or Waveguide | Standard Label ^e |
| | | | $L0 \times 10^{-12} \text{ H}$ | $L1 \times 10^{-24} \text{ H/Hz}$ | $L2 \times 10^{-33} \text{ H/Hz}^2$ | $L3 \times 10^{-42} \text{ H/Hz}^3$ | | Delay in psec | $Z_0 \Omega$ | Loss in GΩ/s | Min | Max | | |
| 1 | 1.85 mm male [SHORT 1] | Short | NA ^f | NA ^f | NA ^f | NA ^f | | NA ^f | 50 | NA ^f | 0 | 73 | Coax | Short 1 -m- |
| 2 | 1.85 mm male [OPEN] | Open | NA ^f | NA ^f | NA ^f | NA ^f | | NA ^f | 50 | NA ^f | 0 | 73 | Coax | Open BB -m- |
| 3 | 1.85 mm female [SHORT 1] | Short | NA ^f | NA ^f | NA ^f | NA ^f | | NA ^f | 50 | NA ^f | 0 | 73 | Coax | Short 1 -f- |
| 4 | 1.85 mm female [OPEN] | Open | NA ^f | NA ^f | NA ^f | NA ^f | | NA ^f | 50 | NA ^f | 0 | 73 | Coax | Open BB -f- |
| 9 | 1.85 mm female broadband load [TERM] | Load | NA ^f | NA ^f | NA ^f | NA ^f | Fixed | NA ^f | 50 | NA ^f | 0 | 73 | Coax | Broadband -f- |
| 11 | Insertable thru standard | Thru | NA ^f | NA ^f | NA ^f | NA ^f | | 0 | 50 | 0 | 0 | 73 | Coax | Thru |
| 24 | 1.85 mm male broadband load [TERM] | Load | NA ^f | NA ^f | NA ^f | NA ^f | Fixed | NA ^f | 50 | NA ^f | 0 | 73 | Coax | Broadband -m- |

- Ensure system Z_0 of network analyzer is set to this value.
- For waveguide, the lower frequency is the same as F_{CO} .
- The description text shown in [square brackets] is present on the calibration device.
- Load or arbitrary impedance only.
- Refer to "Clarifying the Sex of a Connector" on page 1-20.
- The definition for this data-based calibration standard is in a non-editable file in the PNA.

Table A-14 PNA family: 85058EP (Economy kit, Polynomial model) Standard Definitions

| System $Z_0^a = 50 \Omega$ | | Calibration Kit Label: 85058EP Polynomial | | | | | | | | | | | | |
|--|--------------------------------------|--|--------------------------------|-----------------------------------|-------------------------------------|-------------------------------------|-------------------------------|---------------|--------------|--------------|-------------------------------|-----|-------------------|-----------------------------|
| Disk File Name: 85058EP Polynomial.ckt | | | | | | | | | | | | | | |
| Number | Description ^b | Type | $C0 \times 10^{-15} \text{ F}$ | $C1 \times 10^{-27} \text{ F/Hz}$ | $C2 \times 10^{-36} \text{ F/Hz}^2$ | $C3 \times 10^{-45} \text{ F/Hz}^3$ | Fixed or Sliding ^d | Offset | | | Frequency in GHz ^c | | Coax or Waveguide | Standard Label ^e |
| | | | $L0 \times 10^{-12} \text{ H}$ | $L1 \times 10^{-24} \text{ H/Hz}$ | $L2 \times 10^{-33} \text{ H/Hz}^2$ | $L3 \times 10^{-42} \text{ H/Hz}^3$ | | Delay in psec | $Z_0 \Omega$ | Loss in GΩ/s | Min | Max | | |
| 1 | 1.85 mm male [SHORT 1] | Short | 0.9658 | 8.9552 | -0.7884 | 0.0079 | | 18.012 | 50 | 4.0608 | 0 | 999 | Coax | Short 1 BB -m- |
| 2 | 1.85 mm male [OPEN] | Open | 2.2757 | 0.60959 | -3.9739 | 0.05204 | | 18.011 | 50 | 3.2815 | 0 | 999 | Coax | Open BB -m- |
| 3 | 1.85 mm female [SHORT 1] | Short | 1.4957 | -323.18 | 11.624 | -0.10939 | | 18.012 | 50 | 4.0812 | 0 | 999 | Coax | Short 1 BB -f- |
| 4 | 1.85 mm female [OPEN] | Open | -3.5342 | 425.24 | -13.946 | 0.12741 | | 18.001 | 50 | 3.2822 | 0 | 999 | Coax | Open BB -f- |
| 9 | 1.85 mm female broadband load [TERM] | Load | | | | | Fixed | 0 | 50 | 0 | 0 | 999 | Coax | Broadband -f- |
| 11 | Insertable thru standard | Thru | | | | | | 0 | 50 | 0 | 0 | 73 | Coax | Thru |
| 24 | 1.85 mm male broadband load [TERM] | Load | | | | | Fixed | 0 | 50 | 0 | 0 | 999 | Coax | Broadband -m- |

- Ensure system Z_0 of network analyzer is set to this value.
- The description text shown in [square brackets] is present on the calibration device.
- For waveguide, the lower frequency is the same as F_{CO} .
- Load or arbitrary impedance only.
- Refer to "Clarifying the Sex of a Connector" on page 1-20.

Blank Forms

The standard definitions listed in Table A-9 through Table A-14 may be changed to meet your specific requirements. Table A-15 and Table A-16 are provided to record the modified standard definitions.

Table A-15 8510 family: Standard Definitions Blank Form

| System $Z_0 =$ | | | | | | Calibration Kit Label: | | | | | | | |
|-----------------|------|--------------------------------|-----------------------------------|-------------------------------------|-------------------------------------|------------------------|-------------|--------------|--------------|------------------|-----|-------------------|----------------|
| Disk File Name: | | | | | | | | | | | | | |
| Standard | | $C0 \times 10^{-15} \text{ F}$ | $C1 \times 10^{-27} \text{ F/Hz}$ | $C2 \times 10^{-36} \text{ F/Hz}^2$ | $C3 \times 10^{-45} \text{ F/Hz}^3$ | Fixed or Sliding | Offset | | | Frequency in GHz | | Coax or Waveguide | Standard Label |
| Number | Type | $L0 \times 10^{-12} \text{ H}$ | $L1 \times 10^{-24} \text{ H/Hz}$ | $L2 \times 10^{-33} \text{ H/Hz}^2$ | $L3 \times 10^{-42} \text{ H/Hz}^3$ | | Delay in ps | $Z_0 \Omega$ | Loss in GΩ/s | Min | Max | | |
| 1 | | | | | | | | | | | | | |
| 2 | | | | | | | | | | | | | |
| 3 | | | | | | | | | | | | | |
| 4 | | | | | | | | | | | | | |
| 5 | | | | | | | | | | | | | |
| 6 | | | | | | | | | | | | | |
| 7 | | | | | | | | | | | | | |
| 8 | | | | | | | | | | | | | |
| 9 | | | | | | | | | | | | | |
| 10 | | | | | | | | | | | | | |
| 11 | | | | | | | | | | | | | |
| 12 | | | | | | | | | | | | | |
| 13 | | | | | | | | | | | | | |
| 14 | | | | | | | | | | | | | |
| 15 | | | | | | | | | | | | | |
| 16 | | | | | | | | | | | | | |
| 17 | | | | | | | | | | | | | |
| 18 | | | | | | | | | | | | | |
| 19 | | | | | | | | | | | | | |
| 20 | | | | | | | | | | | | | |
| 21 | | | | | | | | | | | | | |

Table A-16 PNA family: Standard Definitions Blank Form

| System $Z_0^a =$ | | Calibration Kit Label: | | | | | | | | | | | | | |
|------------------|-------------|------------------------|------------------------|---------------------------|-----------------------------|-----------------------------|-------------------------------|--------------|--------------|--------------|-------------------------------|-----|-------------------|-----------------------------|--|
| Disk File Name: | | | | | | | | | | | | | | | |
| Number | Description | Type | $C0 \times 10^{-15} F$ | $C1 \times 10^{-27} F/Hz$ | $C2 \times 10^{-36} F/Hz^2$ | $C3 \times 10^{-45} F/Hz^3$ | Fixed or Sliding ^c | Offset | | | Frequency in GHz ^b | | Coax or Waveguide | Standard Label ^d | |
| | | | $L0 \times 10^{-12} H$ | $L1 \times 10^{-24} H/Hz$ | $L2 \times 10^{-33} H/Hz^2$ | $L3 \times 10^{-42} H/Hz^3$ | | Delay in sec | $Z_0 \Omega$ | Loss in GΩ/s | Min | Max | | | |
| 1 | | | | | | | | | | | | | | | |
| 2 | | | | | | | | | | | | | | | |
| 3 | | | | | | | | | | | | | | | |
| 4 | | | | | | | | | | | | | | | |
| 5 | | | | | | | | | | | | | | | |
| 6 | | | | | | | | | | | | | | | |
| 7 | | | | | | | | | | | | | | | |
| 8 | | | | | | | | | | | | | | | |
| 9 | | | | | | | | | | | | | | | |
| 10 | | | | | | | | | | | | | | | |
| 11 | | | | | | | | | | | | | | | |
| 12 | | | | | | | | | | | | | | | |
| 13 | | | | | | | | | | | | | | | |
| 14 | | | | | | | | | | | | | | | |
| 15 | | | | | | | | | | | | | | | |
| 16 | | | | | | | | | | | | | | | |
| 17 | | | | | | | | | | | | | | | |
| 18 | | | | | | | | | | | | | | | |
| 19 | | | | | | | | | | | | | | | |
| 20 | | | | | | | | | | | | | | | |
| 21 | | | | | | | | | | | | | | | |
| 22 | | | | | | | | | | | | | | | |
| 23 | | | | | | | | | | | | | | | |
| 24 | | | | | | | | | | | | | | | |

a. Ensure system Z_0 of network analyzer is set to this value.
 b. For waveguide, the lower frequency is the same as F_{CO} .
 c. Load or arbitrary impedance only.
 d. Refer to "Clarifying the Sex of a Connector" on page 1-20.

Standard Definitions
Nominal Standard Definitions

Numerics

85058B and 85058BP, 1-2

85058E and 85058EP, 1-2

A

adapters, 1-5, 1-6, 1-7

part numbers, 6-8

Agilent Technologies, contacting, 5-3

alcohol, isopropyl, as cleaning solvent, 3-6

altitude, 2-2

B

bands that identify devices, 1-5

blank form

standard class assignments, A-9

standard definitions, A-20

broadband calibration technique

85058E, 1-4

broadband SOLT

calibration standards, 1-9

calibration technique, 1-9

broadband terminations, 1-6

C

cal kit

contents, 1-4

overview, 1-2

return to Agilent, 5-3

serial number, 1-18

calibration

1-Port, 85058B cal kit, 1-10

1-Port, 85058E cal kit, 1-11

2-Port, 85058B cal kit, 1-12

2-Port, 85058E cal kit, 1-13

bad, 5-2

broadband SOLT technique, 85058E, 1-9

certificate of, 4-2

definitions, 1-7

devices

85058B, 6-3

85058E, 6-6

offset-short technique, 85058B, 1-9

temperature, 2-2

calibration definitions

entering, 1-7

permanently stored, 1-7

calibration definitions disk

part number, 6-3, 6-6

calibration error

specifications

85058B Data-Based.ckt, 1-14

85058E Data-Based.ckt, 1-16

calibration kit

contents, 1-4

overview, 1-2

return to Agilent, 5-3

serial number, 1-18

calibration kit labels

85058B cal kit, 1-8

85058E cal kit, 1-9

calibration report, 4-2

calibration sticker, 4-3

calibration technique

85058B, 1-4

85058E, 1-4

certificate of calibration, 4-2

certification, specifications, 2-9

characteristics

mechanical, 2-3

supplemental, 2-3

class assignment

standard, A-2

class assignments

blank form, A-9

cleaning connectors, 3-6

cleaning supplies, 1-7

ordering, 6-8

part numbers, 6-8

compressed air or nitrogen, 3-6

conductor

mating plane, 2-3

connections, 3-2, 3-14, 3-16

cautions in making, 3-14

disconnecting, 3-16

ESD concerns, 3-14

final, 3-14

how to make, 3-14

preliminary, 3-14

undoing, 3-16

using a torque wrench, 3-14

connector

cleaning, 3-6

cleaning supplies, 6-8

damage, 3-3

female, 3-5, 3-12

gaging, 3-8

when to do, 3-9

life, 3-3

male, 3-10

mating plane, 3-6

sex, 1-20

threads, 3-6

visual inspection, 3-3

wear, 3-3

connector contacts

concentricity, 3-4

integrity, 3-4

connector gage

handling, 3-10, 3-12

zeroing, 3-10, 3-12

connector gage accuracy, 3-8

connectors, slotted, 1-20

contacting Agilent Technologies, 5-3

contents

kit, 1-4

copies of this manual, printing, 1-ii

D

damage

Index

- to connectors, 3-3
- damage, shipment, 1-17
- damaged connectors, 3-3
- data, recertification, 4-2
- data-based model, 1-2
- defective connectors, 3-3
- defining calibration standards, two models, 1-2
- definitions
 - calibration, 1-7
 - entering, 1-7
 - permanently stored, 1-7
 - standard, A-11
- deviation from nominal phase, 85058B, 2-5
- deviation from nominal phase, 85058E, 2-8
- device
 - conductor
 - mating plane, 2-3
 - connecting, 3-14
 - disconnecting, 3-16
 - handling, 3-16
 - maintenance, 1-20
 - part numbers, 6-8
 - pin depth, 2-3
 - return to Agilent, 5-3
 - storage, 3-16
 - temperature, 2-2
 - visual inspection, 3-3
- devices
 - how Agilent verifies, 4-2
 - serial numbers, 1-18
- dimensions
 - device
 - center conductor, 2-3
 - outer conductor, 2-3
- disconnections, 3-16
- disk file names
 - 85058E cal kit, 1-9
- disk file names, 85058B cal kit, 1-8
- document, printing copies, 1-ii
- documentation warranty, 1-ii

E

- electrical specifications, 85058B, 2-5
- electrical specifications, 85058E, 2-8
- electrostatic discharge, 3-2
 - supplies
 - part numbers, 6-8
 - when making connections, 3-14
- environmental requirements, 2-2
- equipment
 - required, 1-7
 - required but not supplied, 1-7
 - supplied, 1-4, 6-2, 6-3, 6-6
- error specifications
 - calibration
 - 85058B Data-Based.ckt, 1-14
 - 85058E Data-Based.ckt, 1-16
- ESD, 3-2
 - precautions, 3-2, 3-6
 - protection devices, 1-7

- supplies
 - part numbers, 6-8
 - when making connections, 3-14
- expanded math, 1-3

F

- frequency
 - performance, 1-7
 - range, 85058B, 2-5
 - range, 85058E, 2-8
 - specifications, 85058B, 2-5
 - specifications, 85058E, 2-8

G

- gage
 - connector
 - handling, 3-10, 3-12
 - master, 6-8
 - zeroing, 3-10, 3-12
 - gage master
 - part numbers, 6-8
 - gages, 1-7
 - gaging
 - female connectors, 3-12
 - male connectors, 3-10
 - gaging connectors, 3-8
 - when to do, 3-9

H

- handling, 3-16
- how to identify calibration devices, 1-5
- humidity, 2-2

I

- identifying shorts, opens, & loads, 1-5
- impedance
 - system, A-11
- incoming inspection, 1-17
- inspection
 - damage, 3-3
 - defects, 3-3
 - female connectors, 3-5
 - incoming, 1-17
 - mating plane, 3-5
 - visual, 3-3
- isopropyl alcohol, as cleaning solvent, 3-6

K

- kit
 - contents, 1-4
 - overview, 1-2
 - return to Agilent, 5-3
 - serial number, 1-18

L

- label
 - calibration, 4-3
- loads

lowband, 1-5
lowband loads, 1-5

M

maintenance, 3-2
 preventive, 1-20
maintenance of devices, 1-20
making connections, 3-14
manual
 part number, 6-3, 6-6
manual, printing copies, 1-ii
math, expanded, 1-3
mating plane
 conductor, 2-3
 connector, 3-6
 inspection, 3-5
 surfaces, 3-7
mechanical characteristics, 2-3
mechanical integrity, 2-3
models for defining calibration standards, 1-2

N

nitrogen, 3-6
nominal standard definitions, A-11
numbers, serial, recording, 1-18

O

offset opens, 1-5, 1-6
offset short calibration technique, 85058B, 1-4
offset shorts, 1-5, 1-6
offset-short
 calibration standards, 1-8
 calibration technique, 1-8
open-end wrench, 3-16
 part number, 6-3, 6-6
opens, 1-5, 1-6
ordering parts, 6-2

P

part numbers, 6-2
parts
 ordering, 6-2
 replaceable, 6-2
 required but not supplied, 6-8
PDF copies of this manual, downloading, 1-ii
performance verification, 4-2
 fail, 5-2
pin depth, 2-3
 affect on electrical performance, 2-4
 definition of, 2-3
 effect on electrical specifications, 2-4
 importance of, 2-4
 observed limits, 2-4
 protrusion, 2-3
 recession, 2-3
 typical values, 2-4
Polynomial model, 1-3
preventive maintenance, 1-20
printing copies of this document, 1-ii
protrusion

pin depth, 2-3

R

recertification, 4-3
 how often?, 4-3
 interval, 4-3
 what's included, 4-3
 where to send your kit, 4-3
recession
 pin depth, 2-3
regulations
 environmental, 3-6
replaceable parts, 6-2
requirements
 environmental, 2-2
return loss
 specifications, 85058B, 2-5
 specifications, 85058E, 2-8
return, kit or device, 5-3
rings that identify devices, 1-5

S

serial numbers, recording, 1-18
service, 5-2
service tag, 1-17, 4-3, 5-3
sex, connector, 1-20
shipment
 damage, 1-17
 verifying complete, 1-17
shorts, 1-5, 1-6
slotted connectors, 1-20
SOLT broadband calibration, 1-9
specifications, 2-2
 altitude, 2-2
 calibration errors
 85058E Data-Based.ckt, 1-16
 certification, 2-9
 electrical, 85058B, 2-5
 electrical, 85058E, 2-8
 environmental, 2-2
 frequency, 85058B, 2-5
 frequency, 85058E, 2-8
 humidity, 2-2
 pin depth, 2-4
 return loss, 85058B, 2-5
 return loss, 85058E, 2-8
 temperature, 2-2
 verifying, 4-2
specified frequency performance, 1-7
standard class assignments
 8510 family
 85058B, A-3
 85058E, A-4
 blank form, A-9
 PNA family
 85058B, A-5
 85058BP, A-6
 85058E, A-7
 85058EP, A-8
standard definitions, A-11, A-20

Index

- 8510 family
 - 85058B, A-12
 - 85058E, A-14
 - blank form, A-20
 - nominal, A-11
 - PNA family
 - 85058B, A-14
 - 85058BP, A-14
 - 85058E, A-14
 - 85058EP, A-14
 - standards
 - NIST, 2-9, 4-3
 - static discharge, 3-2
 - sticker
 - calibration, 4-3
 - storage, 3-16
 - altitude, 2-2
 - humidity, 2-2
 - temperature, 2-2
 - supplemental characteristics, 2-3
 - supplies
 - cleaning, 1-7
 - system impedance
 - setting, A-11
- T**
- tag
 - service, 4-3, 5-3
 - tag, service, 1-17
 - temperature
 - calibration, 2-2
 - device, 2-2
 - error-corrected temperature range, 2-2
 - measurement, 2-2
 - operating range, 2-2
 - verification and measurement, 2-2
 - terminations, broadband, 1-6
 - test data, 4-2
 - threads
 - connector, 3-6
 - torque wrench, 3-14
 - part number, 6-3, 6-6
 - specifications, 3-14
 - traceability, 4-2
 - troubleshooting, 5-2
- V**
- verification
 - performance, 4-2
 - temperature, 2-2
 - visual inspection, 3-3
- W**
- warranty, documentation, 1-ii
 - wrench
 - open-end, 3-16
 - part number, 6-3, 6-6
 - undoing connections, 3-16
 - torque
 - part number, 6-3, 6-6